

LXY28161 USER'S MANUAL

JULY 2008
V1.0

CONTENTS

1	Product Description.....	3
1.1	Features	3
1.2	Applied field	3
1.3	Basic Structure Description.....	3
2	LXY28161 Specification.....	3
2.1	Block Diagram and Pin Configuration.....	3
2.2	Maximum Rating	5
2.3	Electrical Characteristics ($V_{DD}=5.0V$)	6
2.4	Switching Characteristics ($V_{DD}=5V$)	7
2.5	Test Circuit for Switching Characteristics	8
2.6	Timing Waveform.....	9
2.6.1	Serial-Port Timing Waveform.....	9
2.6.2	Output-Current Channel Timing Waveform	9
2.7	Constant Current	10
2.8	Setting Output Current.....	10
2.9	Delay Time of Staggered Output	10
2.10	Package Power Dissipation	10
2.11	Usage of Thermal Pad.....	10
2.12	Thermal Protection Function.....	11
2.13	LED Supply Voltage	11
2.14	Switching Noise Reduction.....	11
2.15	Equivalent Circuits of Inputs and Outputs	12
3	Package Outline.....	12

1 Product Description

LXY28161, the 16-channel constant current LED Driver, is designed for LED video applications using internal Wise Pulse Width Modulation (W-PWM) control with selectable 16-bit color depth. LXY28161 saves the 60 Hz images input data in the 8K RAM, then converts into each pixel gray scale of output channel, all output channels can be built with 65536 gray scales and 4800 Hz refresh rate.

LXY28161 has 16 constant-current output channels. Constant output current is invariant to load voltage change. The output current can be preset through an external resistor. LXY28161 supports static and any scan mode (within 16) led displays. The gray scales and refresh rate is user adjustable.



1.1 Features

- Backward compatible with main trend 16-channel constant current IC in package
- 16 constant-current output channels
- 16-bit color depth W-PWM control
- Refresh rate up to 4800Hz
- Schmitt trigger input
- Staggered output delay (reduce EMI)
- Over temperature protection
- Constant output current range: 5V, 5~60mA
- Output current accuracy: between channels: $\pm 3\%$, between ICs: $\pm 6\%$
- Maximum data clock frequency: 25MHz
- 5V supply voltage

1.2 Applied field

- LED video applications

1.3 Basic Structure Description

LXY28161 mainly includes serial-data input, Wise Pulse Width Modulation, constant current controlling circuit, constant current output.

2 LXY28161 Specification

2.1 Block Diagram and Pin Configuration

LXY28161 applies SOP—24 and TSSOP-24 in package outline, Block Diagram and Pin Configuration are as following diagrams:

Block Diagram

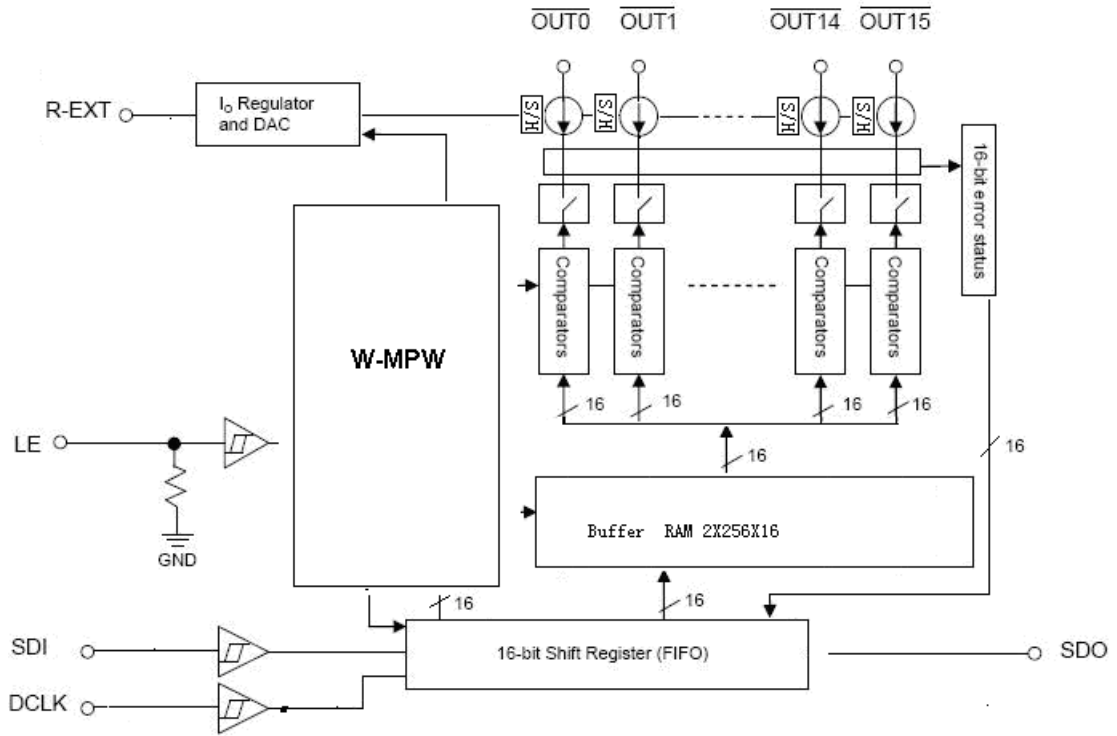

Pin Configuration

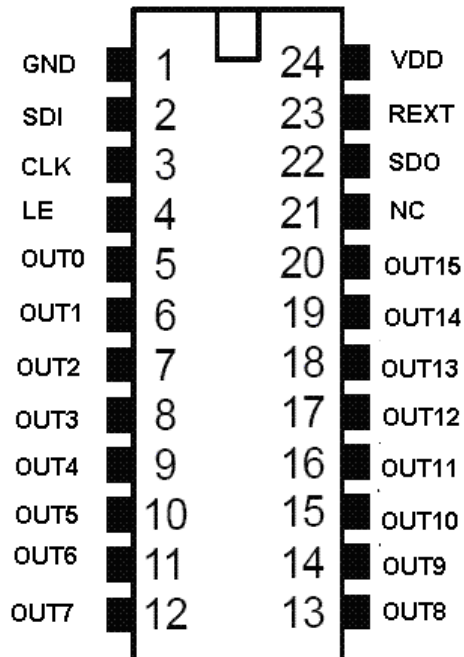

Pin Name	Pin No.	Type	Function
GND	1	Power	Ground terminal for control logic and current sink
SDI	2	Schmitt trigger input	Serial-data input to the shift register
CLK	3	Schmitt trigger input	Clock input terminal for data shift on rising edge
LE	4	Schmitt trigger input	Data strobe terminal and controlling command with DCLK
OUT0~15	5~20	Output	Constant current output terminal, 5-60mA
NC	21	-	-
SDO	22	Controllable staggered output delay	10ns, 20ns, 30ns selectable. Serial-data output to the receiver-end SDI of next driver IC
R-EXT	23	Controlling	Input terminal used to connect an external resistor for setting up output current for all output channels
VDD	24	Power	5V supply voltage terminal

2.2 Maximum Rating

Characteristic		Symbol	Rating	Unit
Supply Voltage		V_{DD}	7	V
Input Pin Voltage (SDI)		V_{IN}	-0.4~ VDD+0.4	V
Output Current		I_{OUT}	+60	mA
Sustaining Voltage at OUT Port		V_{DS}	7	V
Data Clock Frequency		DCLK	+25	MHz
GND Terminal Current		I_{GND}	+1000	mA
Power Dissipation (On PCB, Ta=25° C)	L Type	P_D	2.12	W
	S Type	P_D	1.73	W
Thermal Resistance (On PCB, Ta=25° C)	L Type	$R_{th(j-a)}$	59.1	° C/W
	S Type		72.43	
Operating Temperature		T_{opr}	-40~+85	° C
Storage Temperature		T_{stg}	-55~+150	° C

2.3 Electrical Characteristics (V_{DD}=5.0V)

Characteristics		Symbol	Condition	Min.	Typ.	Max.	Unit
Supply Voltage		V _{DD}	-	3.3	5.0	5.5	V
Sustaining Voltage at OUT Ports		V _{DS}	OUT0 ~ OUT15	-	-	VDD+0.4	V
Output Current		I _{OUT}	Refer to "Test Circuit for Electrical Characteristics"	5	-	60	mA
		I _{OH}	SDO	-	-	-6.0	mA
		I _{OL}	SDO	-	-	6.0	mA
Input Voltage	"H" level	V _{IH}	Ta=-40~85°C	0.7*VDD	-	VDD	V
	"L" level	V _{IL}	Ta=-40~85°C	GND	-	0.3*VDD	V
Output Leakage Current		I _{OH}	V _{DS} =7.0V	-	-	0.5	μA
Output Voltage	SDO	V _{OL}	I _{OL} =+6.0mA	-	-	0.4	V
		V _{OH}	I _{OH} =-6.0mA	4.6	-	-	V
Current Skew (Channel)		ΔI _{OUT1}	I _{OUT} =10.8mA V _{DS} =1.0V R _{ext} =1800Ω	-	±1.5	±3.0	%
Current Skew (IC)		ΔI _{OUT2}	I _{OUT} =10.8mA V _{DS} =1.0V R _{ext} =1800Ω	-	±3.0	±6.0	%
Output Current vs. Output Voltage Regulation		%/ΔV _{DS}	V _{DS} = 1.0V and 3.0V, R _{ext} =910Ω@21mA	-	±0.1	±0.5	% / V
Output Current vs. Output Voltage Regulation		%/dV _{DD}	V _{DD} = 4.5V and 5.5V	-	±1.0	±5.0	% / V
Pull-down Resistor		R _{IN(d own)}	LE	250	500	800	KΩ
Supply Current	"Off"	I _{DD(Off)1}	R _{ext} =Open OUT0 ~ OUT15 =Off	-	11.4	12.5	mA
		I _{DD(Off)2}	R _{ext} =1800Ω OUT0 ~ OUT15 =Off	-	12.3	13.5	
		I _{DD(Off)3}	R _{ext} =910Ω OUT0 ~ OUT15 =Off	-	13.7	15.0	
	"On"	I _{DD(On)1}	R _{ext} =1800Ω OUT0 ~ OUT15 =On	-	14.2	15.7	
		I _{DD(On)2}	R _{ext} =91Ω OUT0 ~ OUT15 =On	-	16.3	18.5	
Thermal Flag Temperature		TTF	Junction Temperature	135	150	165	°C

2.4 Switching Characteristics (V_{DD}=5V)

Characteristics		Symbol	Condition	Min.	Typ.	Max	Unit
Setup Time	SDI - DCLK↑	t _{SU0}		1	-	-	ns
	LE↑ - DCLK↑	t _{SU1}		1	-	-	ns
	LE↓ - DCLK↑	t _{SU2}		5	-	-	ns
Hold Time	DCLK↑ - SDI	t _{H0}		3	-	-	ns
	DCLK↑ - LE↓	t _{H1}		7	-	-	ns
Propagation Delay Time	DCLK - SDO (adjustable)	t _{PD0}	VDD=5.0V VIH=VDD VIL=GND	5	10	20	ns
				15	20	30	ns
				25	30	40	ns
	DCLK output to the receiver-end SDI of next driver IC						
	GCLK - OUT4n	t _{PD1}		*	75	-	ns
Stagger Delay Time	OUT4n + 1*	t _{DL1}	RL=152Ω CL=10pF C1=100nF C2=10μF	-	25	-	ns
	OUT4n + 2 *	t _{DL2}		-	50	-	ns
	OUT4n + 3 *	t _{DL3}		-	75	-	ns
Pulse Width	LE	t _{w(L)}		5	-	-	ns
	DCLK	t _{w(DCLK)}		20	-	-	ns
Output Rise Time of Output Ports		t _{OR}		-	10	20	ns
Output Fall Time of Output Ports		t _{OF}		-	10	20	ns
* Refer to the Timing Waveform, when n=0, 1, 2, 3.							

2.5 Test Circuit for Switching Characteristics

Test Circuit for Switching Characteristics

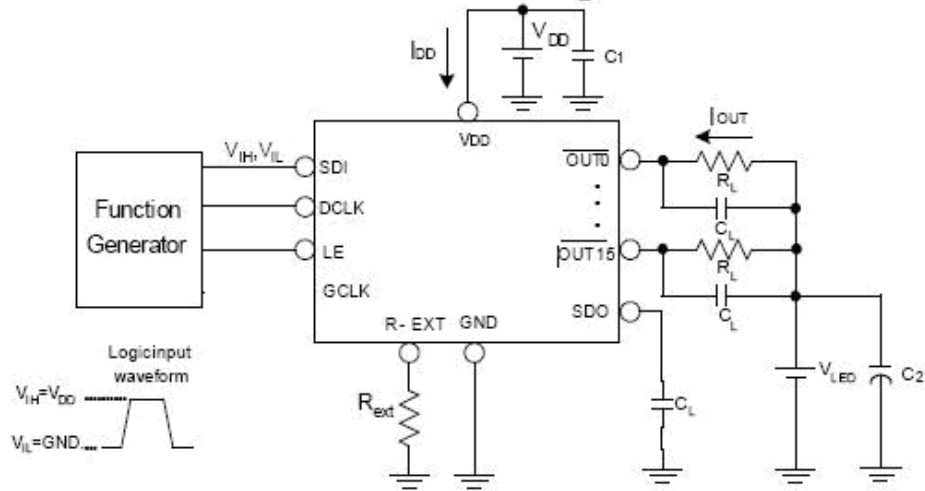

2.6 Timing Waveform

2.6.1 Serial-Port Timing Waveform

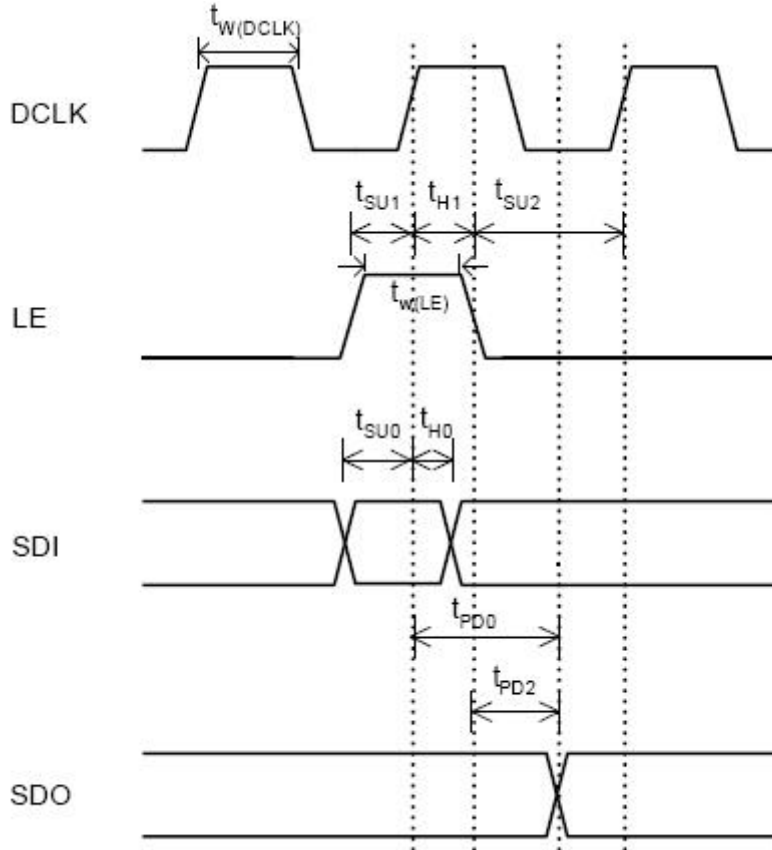

2.6.2 Output-Current Channel Timing Waveform

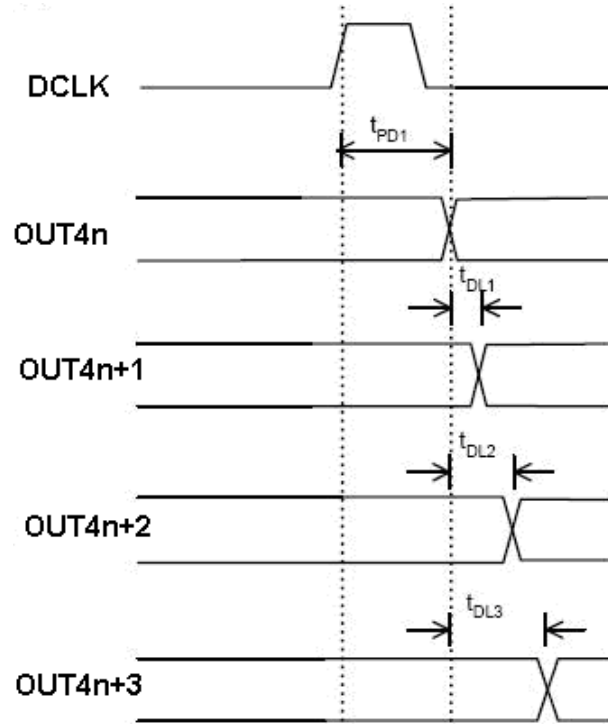

2.7 Constant Current

In LED display application, LXY28161 provides nearly no variation in current from channel to channel and from IC to IC. This can be achieved by:

- 1) The typical current variation between channels is less than $\pm 3\%$, and that between IC is less than $\pm 6\%$.
- 2) In addition, the output current can be kept constant regardless of LED forward voltages. This guarantees LED to be performed on the same brightness as user's specification.

2.8 Setting Output Current

The output current (I_{OUT}) is set by an external resistor, R_{ext} . The default relationship between I_{OUT} and R_{ext} is:

$$V_{R-EXT}=1.26V ;$$

$$I_{OUT}=(V_{R-EXT}/R_{ext}) \times 15.5$$

R_{ext} is the resistance of the external connected to R-EXT terminal

V_{R-EXT} is its voltage

The output current is about 21mA when $R_{ext}=910\Omega$ and 10.8mA when $R_{ext}=1800\Omega$

2.9 Delay Time of Staggered Output

LXY28161 has a built-in staggered circuit to perform delay mechanism. 16 channels are divided to four groups. Each output port has 25nS delay time, so that the instant current from the power line will be lowered.

2.10 Package Power Dissipation

The maximum allowable package power dissipation is determined as

$$P_D(\max)=(T_j - T_a)/R_{th}(j-a).$$

When 16 output channels are turned on simultaneously, the actual package power dissipation is

$$P_D(\text{act})=(I_{DD} \times V_{DD})+(I_{OUT} \times \text{Duty} \times V_{DS} \times 16).$$

Therefore, to keep $P_D(\text{act}) \leq P_D(\max)$, the allowable maximum output current as a function of duty cycle is:

$$I_{OUT}=\{[(T_j - T_a)/R_{th}(j-a)] - (I_{DD} \times V_{DD})\} / (\text{Duty} \times V_{DS} \times 16), \quad (T_j=150^\circ \text{C})$$

The maximum power dissipation, $P_D(\max)=(T_j - T_a)/R_{th}(j-a)$, decreases as the ambient temperature increases. So the LXY28161 must work in Safe Operation Area.

2.11 Usage of Thermal Pad

The PCB area L2xW2 is 4 times of the IC's area L1xW1.

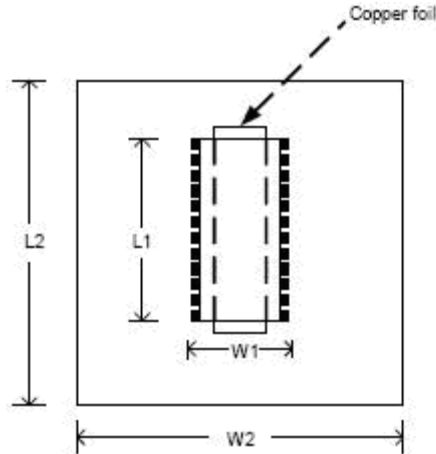

2.12 Thermal Protection Function

The thermal protection function is enabled by default. The output current will decrease to 25%. As soon as the temperature is below 110°C, the thermal error flag will return to 0 and the output current will recover from the 25% current.

2.13 LED Supply Voltage

LXY28161 are designed to operate with VDS ranging from 0.4V to 0.8V (depending on IO_{UT}=5 ~ 60mA), considering the package power dissipating limits. VDS may be higher enough to make when VLED=5V, PD_(act) < PD_(max) when VLED=5V and VDS=VLED - VF, in which VLED is the load supply voltage. In this case, it is recommended to use the lowest possible supply voltage or to set an external voltage reducer, VDROP. A voltage reducer lets VDS=(VLED - VF) - VDROP. Resistors or Zener diode can be used in the applications as shown in the following figures.

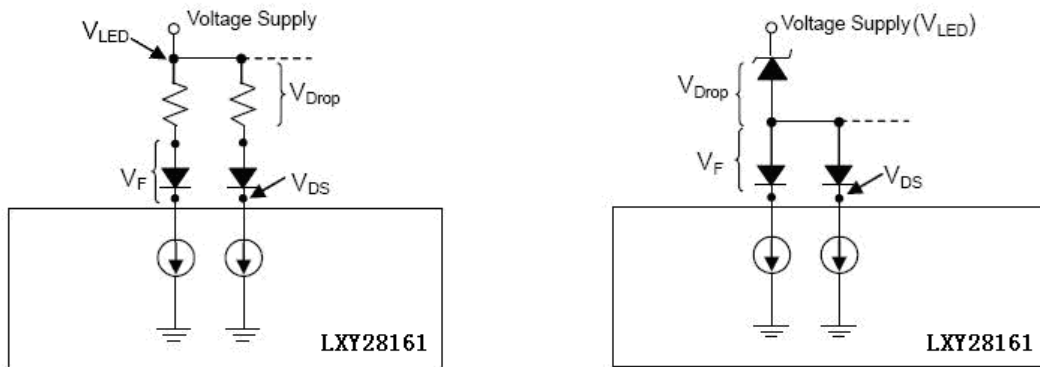

2.14 Switching Noise Reduction

LED drivers are frequently used in switch-mode applications which always behave with switching noise due to the parasitic inductance on PCB. To eliminate switching noise, refer to Application Note for 8-bit and 16-bit LED Drivers-Overshoot.

2.15 Equivalent Circuits of Inputs and Outputs

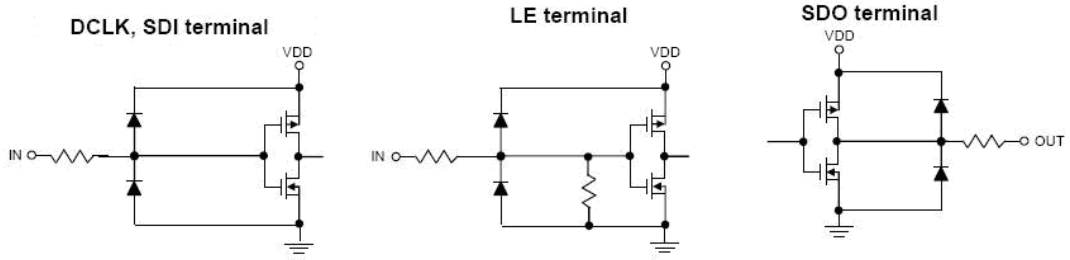

Equivalent circuits of Inputs and Outputs

3 Package Outline

LXY2816 applies SOP-24 and TSSOP-24 package outline:

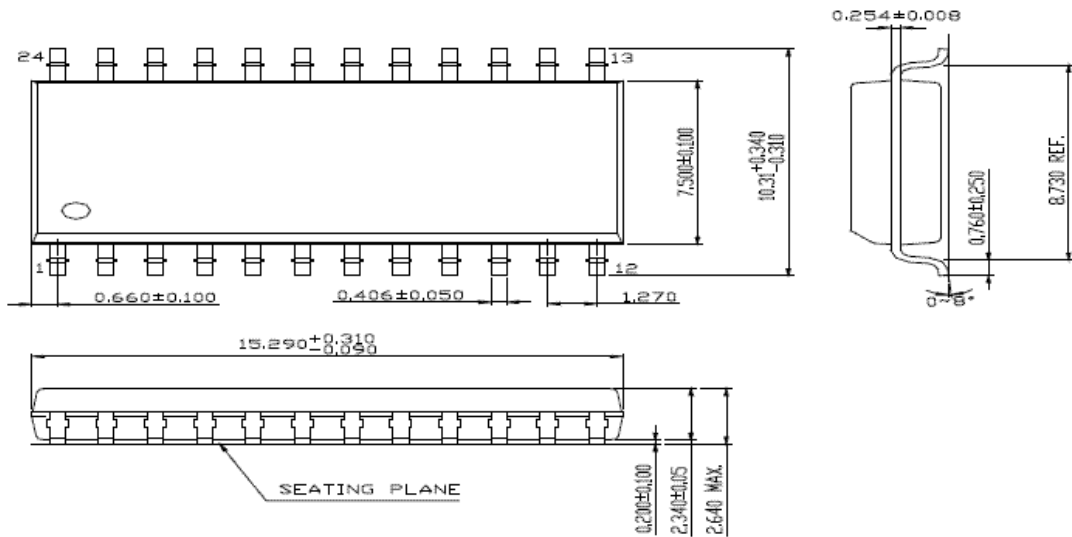

SOP-24 Outline Drawing

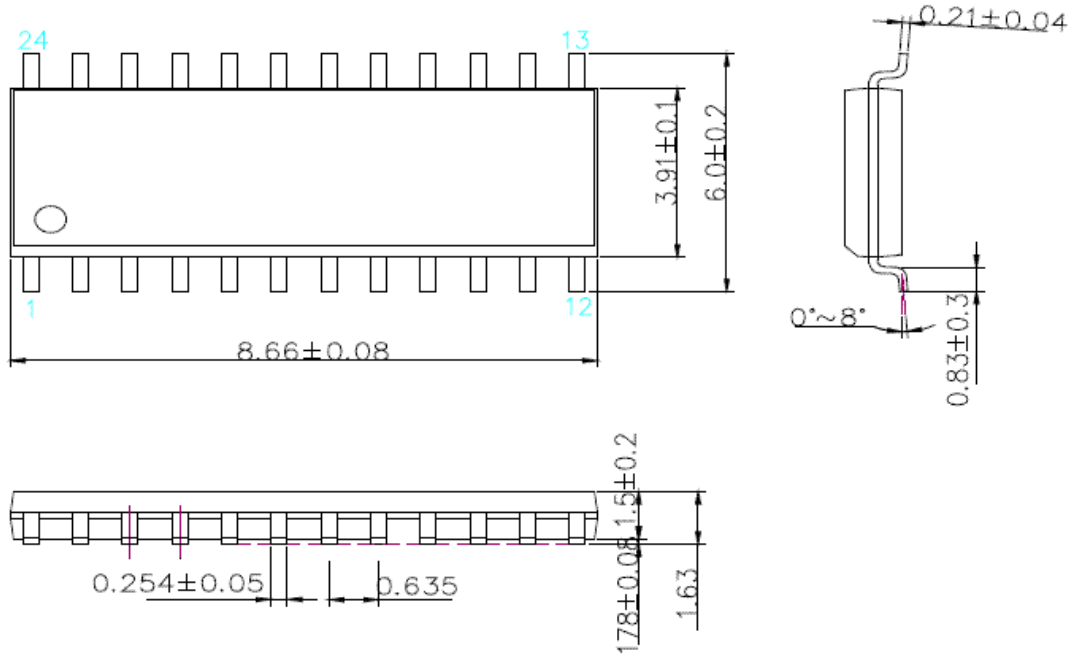

SSOP-24 Outline Drawing