

## Features

- High-performance, Low-power AVR<sup>®</sup> 8-bit Microcontroller
- Advanced RISC Architecture
  - 131 Powerful Instructions – Most Single-clock Cycle Execution
  - 32 x 8 General Purpose Working Registers
  - Fully Static Operation
  - Up to 20 MIPS Throughput at 20 MHz
  - On-chip 2-cycle Multiplier
- High Endurance Non-volatile Memory segments
  - 16/32/64K Bytes of In-System Self-programmable Flash program memory (ATmega164PA/324PA/644PA)
  - 512B/1K/2K Bytes EEPROM (ATmega164PA/324PA/644PA)
  - 1/2/4K Bytes Internal SRAM (ATmega164PA/324PA/644PA)
  - Write/Erase Cycles: 10,000 Flash/ 100,000 EEPROM
  - Data retention: 20 years at 85°C/ 100 years at 25°C<sup>(1)</sup>
  - Optional Boot Code Section with Independent Lock Bits In-System Programming by On-chip Boot Program True Read-While-Write Operation
    - Programming Lock for Software Security
- JTAG (IEEE std. 1149.1 Compliant) Interface
  - Boundary-scan Capabilities According to the JTAG Standard
  - Extensive On-chip Debug Support
  - Programming of Flash, EEPROM, Fuses, and Lock Bits through the JTAG Interface
- Peripheral Features
  - Two 8-bit Timer/Counters with Separate Prescalers and Compare Modes
  - One 16-bit Timer/Counter with Separate Prescaler, Compare Mode, and Capture Mode
  - Real Time Counter with Separate Oscillator
  - Six PWM Channels
  - 8-channel, 10-bit ADC
    - Differential mode with selectable gain at 1x, 10x or 200x
  - Byte-oriented Two-wire Serial Interface
  - Two Programmable Serial USART
  - Master/Slave SPI Serial Interface
  - Programmable Watchdog Timer with Separate On-chip Oscillator
  - On-chip Analog Comparator
  - Interrupt and Wake-up on Pin Change
- Special Microcontroller Features
  - Power-on Reset and Programmable Brown-out Detection
  - Internal Calibrated RC Oscillator
  - External and Internal Interrupt Sources
  - Six Sleep Modes: Idle, ADC Noise Reduction, Power-save, Power-down, Standby and Extended Standby
- I/O and Packages
  - 32 Programmable I/O Lines
  - 40-pin PDIP, 44-lead TQFP, 44-pad VQFN/QFN/MLF
  - 44-pad DRQFN
  - 49-ball VFBGA
- Operating Voltages
  - 1.8 - 5.5V
- Speed Grades
  - 0 - 20MHz @ 1.8 - 5.5V
- Power Consumption at 1 MHz, 1.8V, 25°C
  - Active: 0.4 mA
  - Power-down Mode: 0.1µA
  - Power-save Mode: 0.6µA (Including 32 kHz RTC)

Note: 1. See "Data Retention" on page 9 for details.



## 8-bit AVR<sup>®</sup> Microcontroller with 16/32/64K Bytes In-System Programmable Flash

ATmega164PA  
ATmega324PA  
ATmega644PA

## Summary

Rev. 8152FS-AVR-10/09



# 1. Pin Configurations

## 1.1 Pinout - PDIP/TQFP/VQFN/QFN/MLF

Figure 1-1. Pinout

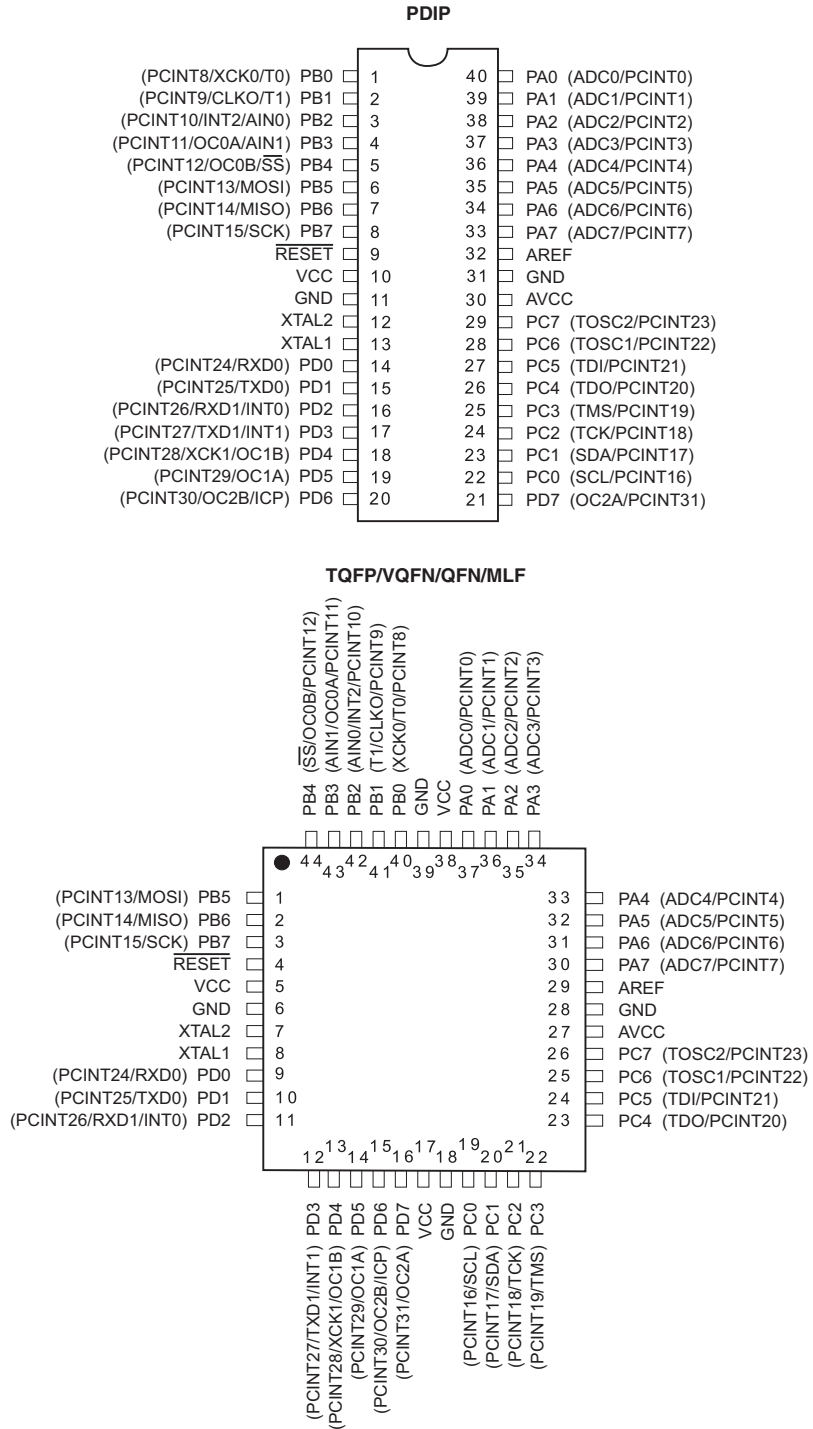

Note: The large center pad underneath the VQFN/QFN/MLF package should be soldered to ground on the board to ensure good mechanical stability.

## 1.2 Pinout - DRQFN

Figure 1-2. DRQFN - Pinout

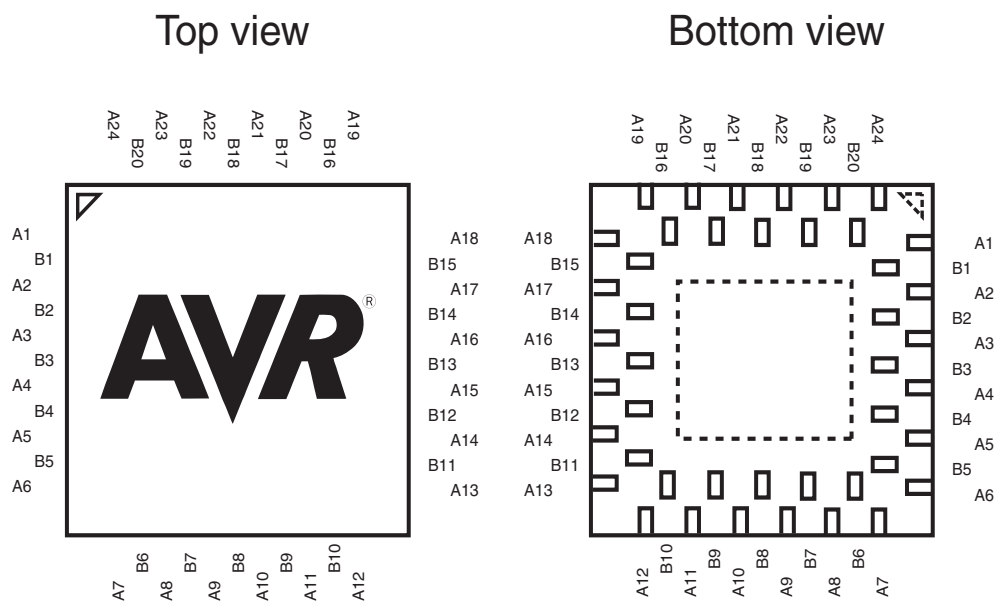

Table 1-1. DRQFN - Pinout

|           |       |            |     |            |      |            |     |
|-----------|-------|------------|-----|------------|------|------------|-----|
| <b>A1</b> | PB5   | <b>A7</b>  | PD3 | <b>A13</b> | PC4  | <b>A19</b> | PA3 |
| <b>B1</b> | PB6   | <b>B6</b>  | PD4 | <b>B11</b> | PC5  | <b>B16</b> | PA2 |
| <b>A2</b> | PB7   | <b>A8</b>  | PD5 | <b>A14</b> | PC6  | <b>A20</b> | PA1 |
| <b>B2</b> | RESET | <b>B7</b>  | PD6 | <b>B12</b> | PC7  | <b>B17</b> | PA0 |
| <b>A3</b> | VCC   | <b>A9</b>  | PD7 | <b>A15</b> | AVCC | <b>A21</b> | VCC |
| <b>B3</b> | GND   | <b>B8</b>  | VCC | <b>B13</b> | GND  | <b>B18</b> | GND |
| <b>A4</b> | XTAL2 | <b>A10</b> | GND | <b>A16</b> | AREF | <b>A22</b> | PB0 |
| <b>B4</b> | XTAL1 | <b>B9</b>  | PC0 | <b>B14</b> | PA7  | <b>B19</b> | PB1 |
| <b>A5</b> | PD0   | <b>A11</b> | PC1 | <b>A17</b> | PA6  | <b>A23</b> | PB2 |
| <b>B5</b> | PD1   | <b>B10</b> | PC2 | <b>B15</b> | PA5  | <b>B20</b> | PB3 |
| <b>A6</b> | PD2   | <b>A12</b> | PC3 | <b>A18</b> | PA4  | <b>A24</b> | PB4 |

### 1.3 Pinout - VFBGA

Figure 1-3. VFBGA - Pinout

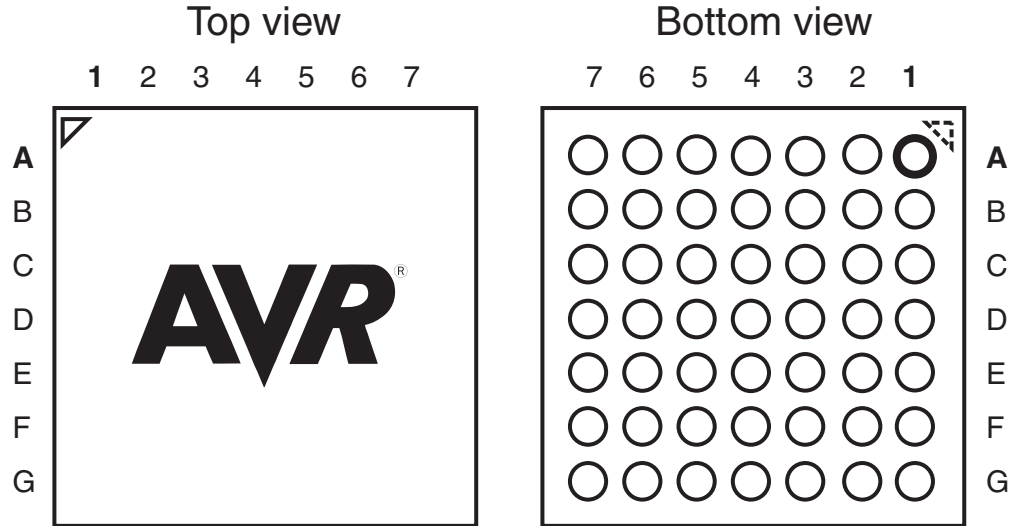

Table 1-2. BGA - Pinout

|   | 1     | 2     | 3   | 4   | 5   | 6   | 7    |
|---|-------|-------|-----|-----|-----|-----|------|
| A | GND   | PB4   | PB2 | GND | VCC | PA2 | GND  |
| B | PB6   | PB5   | PB3 | PB0 | PA0 | PA3 | PA5  |
| C | VCC   | RESET | PB7 | PB1 | PA1 | PA6 | AREF |
| D | GND   | XTAL2 | PD0 | GND | PA4 | PA7 | GND  |
| E | XTAL1 | PD1   | PD5 | PD7 | PC5 | PC7 | AVCC |
| F | PD2   | PD3   | PD6 | PC0 | PC2 | PC4 | PC6  |
| G | GND   | PD4   | VCC | GND | PC1 | PC3 | GND  |

## 2. Overview

The ATmega164PA/324PA/644PA is a low-power CMOS 8-bit microcontroller based on the AVR enhanced RISC architecture. By executing powerful instructions in a single clock cycle, the ATmega164PA/324PA/644PA achieves throughputs approaching 1 MIPS per MHz allowing the system designer to optimize power consumption versus processing speed.

### 2.1 Block Diagram

Figure 2-1. Block Diagram

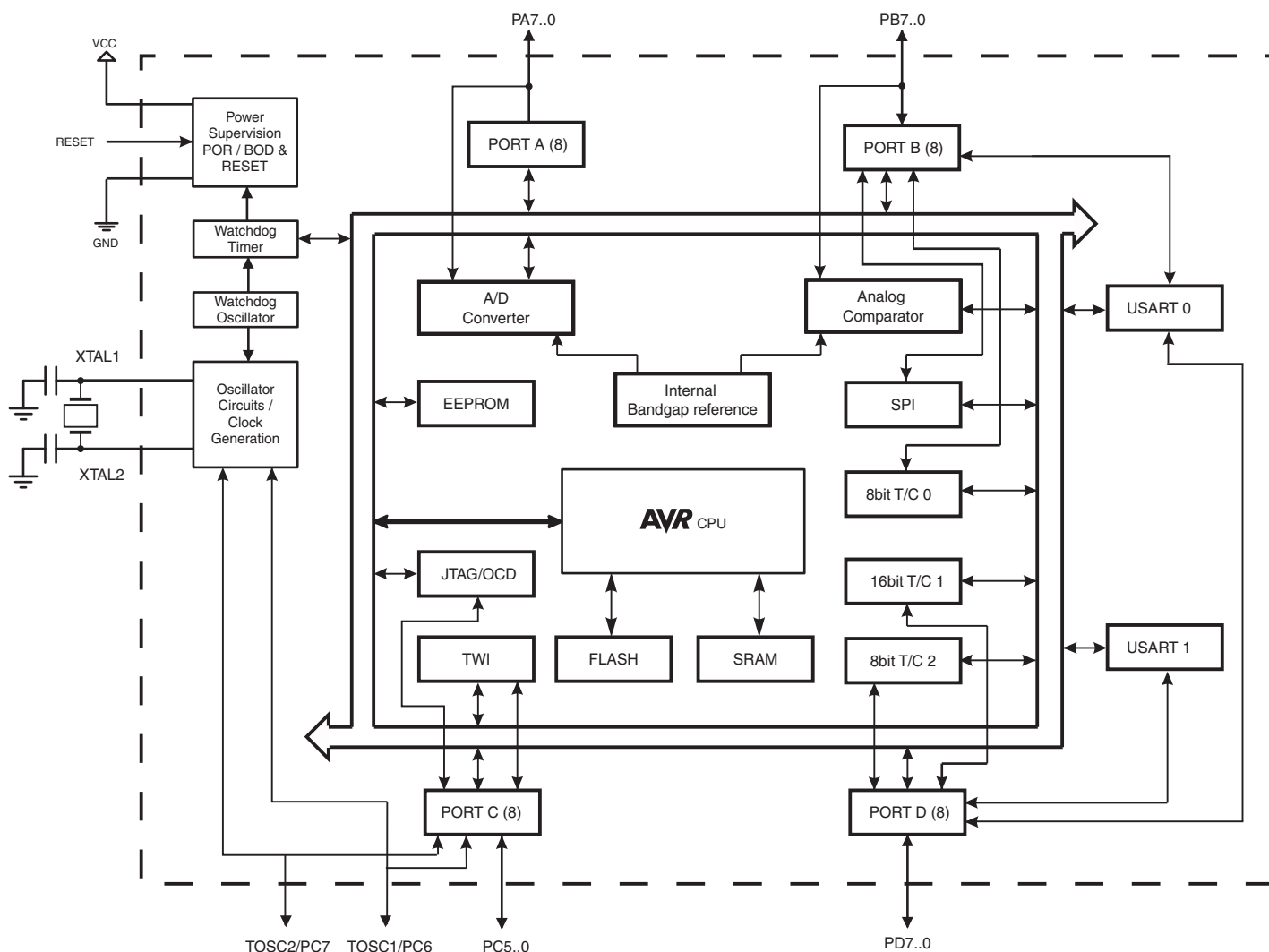

The AVR core combines a rich instruction set with 32 general purpose working registers. All the 32 registers are directly connected to the Arithmetic Logic Unit (ALU), allowing two independent registers to be accessed in one single instruction executed in one clock cycle. The resulting architecture is more code efficient while achieving throughputs up to ten times faster than conventional CISC microcontrollers.



The ATmega164PA/324PA/644PA provides the following features: 16/32/64K bytes of In-System Programmable Flash with Read-While-Write capabilities, 512B/1K/2K bytes EEPROM, 1/2/4K bytes SRAM, 32 general purpose I/O lines, 32 general purpose working registers, Real Time Counter (RTC), three flexible Timer/Counters with compare modes and PWM, 2 USARTs, a byte oriented 2-wire Serial Interface, a 8-channel, 10-bit ADC with optional differential input stage with programmable gain, programmable Watchdog Timer with Internal Oscillator, an SPI serial port, IEEE std. 1149.1 compliant JTAG test interface, also used for accessing the On-chip Debug system and programming and six software selectable power saving modes. The Idle mode stops the CPU while allowing the SRAM, Timer/Counters, SPI port, and interrupt system to continue functioning. The Power-down mode saves the register contents but freezes the Oscillator, disabling all other chip functions until the next interrupt or Hardware Reset. In Power-save mode, the asynchronous timer continues to run, allowing the user to maintain a timer base while the rest of the device is sleeping. The ADC Noise Reduction mode stops the CPU and all I/O modules except Asynchronous Timer and ADC, to minimize switching noise during ADC conversions. In Standby mode, the Crystal/Resonator Oscillator is running while the rest of the device is sleeping. This allows very fast start-up combined with low power consumption. In Extended Standby mode, both the main Oscillator and the Asynchronous Timer continue to run.

The device is manufactured using Atmel's high-density nonvolatile memory technology. The On-chip ISP Flash allows the program memory to be reprogrammed in-system through an SPI serial interface, by a conventional nonvolatile memory programmer, or by an On-chip Boot program running on the AVR core. The boot program can use any interface to download the application program in the application Flash memory. Software in the Boot Flash section will continue to run while the Application Flash section is updated, providing true Read-While-Write operation. By combining an 8-bit RISC CPU with In-System Self-Programmable Flash on a monolithic chip, the Atmel ATmega164PA/324PA/644PA is a powerful microcontroller that provides a highly flexible and cost effective solution to many embedded control applications.

The ATmega164PA/324PA/644PA AVR is supported with a full suite of program and system development tools including: C compilers, macro assemblers, program debugger/simulators, in-circuit emulators, and evaluation kits.

## 2.2 Comparison Between ATmega164PA, ATmega324PA and ATmega644PA

**Table 2-1.** Differences between ATmega164PA, ATmega324PA and ATmega644PA

| Device      | Flash    | EEPROM    | RAM     |
|-------------|----------|-----------|---------|
| ATmega164PA | 16 Kbyte | 512 Bytes | 1 Kbyte |
| ATmega324PA | 32 Kbyte | 1 Kbyte   | 2 Kbyte |
| ATmega644PA | 64 Kbyte | 2 Kbyte   | 4 Kbyte |

## 2.3 Pin Descriptions

### 2.3.1 VCC

Digital supply voltage.

### 2.3.2 GND

Ground.

### 2.3.3 Port A (PA7:PA0)

Port A serves as analog inputs to the Analog-to-digital Converter.

Port A also serves as an 8-bit bi-directional I/O port with internal pull-up resistors (selected for each bit). The Port A output buffers have symmetrical drive characteristics with both high sink and source capability. As inputs, Port A pins that are externally pulled low will source current if the pull-up resistors are activated. The Port A pins are tri-stated when a reset condition becomes active, even if the clock is not running.

Port A also serves the functions of various special features of the ATmega164PA/324PA/644PA as listed on [page 81](#).

### 2.3.4 Port B (PB7:PB0)

Port B is an 8-bit bi-directional I/O port with internal pull-up resistors (selected for each bit). The Port B output buffers have symmetrical drive characteristics with both high sink and source capability. As inputs, Port B pins that are externally pulled low will source current if the pull-up resistors are activated. The Port B pins are tri-stated when a reset condition becomes active, even if the clock is not running.

Port B also serves the functions of various special features of the ATmega164PA/324PA/644PA as listed on [page 83](#).

### 2.3.5 Port C (PC7:PC0)

Port C is an 8-bit bi-directional I/O port with internal pull-up resistors (selected for each bit). The Port C output buffers have symmetrical drive characteristics with both high sink and source capability. As inputs, Port C pins that are externally pulled low will source current if the pull-up resistors are activated. The Port C pins are tri-stated when a reset condition becomes active, even if the clock is not running.

Port C also serves the functions of the JTAG interface, along with special features of the ATmega164PA/324PA/644PA as listed on [page 86](#).

### 2.3.6 Port D (PD7:PD0)

Port D is an 8-bit bi-directional I/O port with internal pull-up resistors (selected for each bit). The Port D output buffers have symmetrical drive characteristics with both high sink and source capability. As inputs, Port D pins that are externally pulled low will source current if the pull-up resistors are activated. The Port D pins are tri-stated when a reset condition becomes active, even if the clock is not running.

Port D also serves the functions of various special features of the ATmega164PA/324PA/644PA as listed on [page 88](#).

### **2.3.7    RESET**

Reset input. A low level on this pin for longer than the minimum pulse length will generate a reset, even if the clock is not running. The minimum pulse length is given in "[System and Reset Characteristics](#)" on page 330. Shorter pulses are not guaranteed to generate a reset.

### **2.3.8    XTAL1**

Input to the inverting Oscillator amplifier and input to the internal clock operating circuit.

### **2.3.9    XTAL2**

Output from the inverting Oscillator amplifier.

### **2.3.10   AVCC**

AVCC is the supply voltage pin for Port A and the Analog-to-digital Converter. It should be externally connected to  $V_{CC}$ , even if the ADC is not used. If the ADC is used, it should be connected to  $V_{CC}$  through a low-pass filter.

### **2.3.11   AREF**

This is the analog reference pin for the Analog-to-digital Converter.



## 3. Resources

A comprehensive set of development tools, application notes and datasheets are available for download on <http://www.atmel.com/avr>.

## 4. About Code Examples

This documentation contains simple code examples that briefly show how to use various parts of the device. Be aware that not all C compiler vendors include bit definitions in the header files and interrupt handling in C is compiler dependent. Please confirm with the C compiler documentation for more details.

The code examples assume that the part specific header file is included before compilation. For I/O registers located in extended I/O map, "IN", "OUT", "SBIS", "SBIC", "CBI", and "SBI" instructions must be replaced with instructions that allow access to extended I/O. Typically "LDS" and "STS" combined with "SBRS", "SBRC", "SBR", and "CBR".

## 5. Data Retention

Reliability Qualification results show that the projected data retention failure rate is much less than 1 PPM over 20 years at 85°C or 100 years at 25°C.



## 6. Register Summary

| Address | Name     | Bit 7                              | Bit 6   | Bit 5  | Bit 4 | Bit 3                               | Bit 2  | Bit 1  | Bit 0  | Page    |
|---------|----------|------------------------------------|---------|--------|-------|-------------------------------------|--------|--------|--------|---------|
| (0xFF)  | Reserved | -                                  | -       | -      | -     | -                                   | -      | -      | -      |         |
| (0xFE)  | Reserved | -                                  | -       | -      | -     | -                                   | -      | -      | -      |         |
| (0xFD)  | Reserved | -                                  | -       | -      | -     | -                                   | -      | -      | -      |         |
| (0xFC)  | Reserved | -                                  | -       | -      | -     | -                                   | -      | -      | -      |         |
| (0xFB)  | Reserved | -                                  | -       | -      | -     | -                                   | -      | -      | -      |         |
| (0xFA)  | Reserved | -                                  | -       | -      | -     | -                                   | -      | -      | -      |         |
| (0xF9)  | Reserved | -                                  | -       | -      | -     | -                                   | -      | -      | -      |         |
| (0xF8)  | Reserved | -                                  | -       | -      | -     | -                                   | -      | -      | -      |         |
| (0xF7)  | Reserved | -                                  | -       | -      | -     | -                                   | -      | -      | -      |         |
| (0xF6)  | Reserved | -                                  | -       | -      | -     | -                                   | -      | -      | -      |         |
| (0xF5)  | Reserved | -                                  | -       | -      | -     | -                                   | -      | -      | -      |         |
| (0xF4)  | Reserved | -                                  | -       | -      | -     | -                                   | -      | -      | -      |         |
| (0xF3)  | Reserved | -                                  | -       | -      | -     | -                                   | -      | -      | -      |         |
| (0xF2)  | Reserved | -                                  | -       | -      | -     | -                                   | -      | -      | -      |         |
| (0xF1)  | Reserved | -                                  | -       | -      | -     | -                                   | -      | -      | -      |         |
| (0xF0)  | Reserved | -                                  | -       | -      | -     | -                                   | -      | -      | -      |         |
| (0xEF)  | Reserved | -                                  | -       | -      | -     | -                                   | -      | -      | -      |         |
| (0xEE)  | Reserved | -                                  | -       | -      | -     | -                                   | -      | -      | -      |         |
| (0xED)  | Reserved | -                                  | -       | -      | -     | -                                   | -      | -      | -      |         |
| (0xEC)  | Reserved | -                                  | -       | -      | -     | -                                   | -      | -      | -      |         |
| (0xEB)  | Reserved | -                                  | -       | -      | -     | -                                   | -      | -      | -      |         |
| (0xEA)  | Reserved | -                                  | -       | -      | -     | -                                   | -      | -      | -      |         |
| (0xE9)  | Reserved | -                                  | -       | -      | -     | -                                   | -      | -      | -      |         |
| (0xE8)  | Reserved | -                                  | -       | -      | -     | -                                   | -      | -      | -      |         |
| (0xE7)  | Reserved | -                                  | -       | -      | -     | -                                   | -      | -      | -      |         |
| (0xE6)  | Reserved | -                                  | -       | -      | -     | -                                   | -      | -      | -      |         |
| (0xE5)  | Reserved | -                                  | -       | -      | -     | -                                   | -      | -      | -      |         |
| (0xE4)  | Reserved | -                                  | -       | -      | -     | -                                   | -      | -      | -      |         |
| (0xE3)  | Reserved | -                                  | -       | -      | -     | -                                   | -      | -      | -      |         |
| (0xE2)  | Reserved | -                                  | -       | -      | -     | -                                   | -      | -      | -      |         |
| (0xE1)  | Reserved | -                                  | -       | -      | -     | -                                   | -      | -      | -      |         |
| (0xE0)  | Reserved | -                                  | -       | -      | -     | -                                   | -      | -      | -      |         |
| (0xDF)  | Reserved | -                                  | -       | -      | -     | -                                   | -      | -      | -      |         |
| (0xDE)  | Reserved | -                                  | -       | -      | -     | -                                   | -      | -      | -      |         |
| (0xDD)  | Reserved | -                                  | -       | -      | -     | -                                   | -      | -      | -      |         |
| (0xDC)  | Reserved | -                                  | -       | -      | -     | -                                   | -      | -      | -      |         |
| (0xDB)  | Reserved | -                                  | -       | -      | -     | -                                   | -      | -      | -      |         |
| (0xDA)  | Reserved | -                                  | -       | -      | -     | -                                   | -      | -      | -      |         |
| (0xD9)  | Reserved | -                                  | -       | -      | -     | -                                   | -      | -      | -      |         |
| (0xD8)  | Reserved | -                                  | -       | -      | -     | -                                   | -      | -      | -      |         |
| (0xD7)  | Reserved | -                                  | -       | -      | -     | -                                   | -      | -      | -      |         |
| (0xD6)  | Reserved | -                                  | -       | -      | -     | -                                   | -      | -      | -      |         |
| (0xD5)  | Reserved | -                                  | -       | -      | -     | -                                   | -      | -      | -      |         |
| (0xD4)  | Reserved | -                                  | -       | -      | -     | -                                   | -      | -      | -      |         |
| (0xD3)  | Reserved | -                                  | -       | -      | -     | -                                   | -      | -      | -      |         |
| (0xD2)  | Reserved | -                                  | -       | -      | -     | -                                   | -      | -      | -      |         |
| (0xD1)  | Reserved | -                                  | -       | -      | -     | -                                   | -      | -      | -      |         |
| (0xD0)  | Reserved | -                                  | -       | -      | -     | -                                   | -      | -      | -      |         |
| (0xCF)  | Reserved | -                                  | -       | -      | -     | -                                   | -      | -      | -      |         |
| (0xCE)  | UDR1     | USART1 I/O Data Register           |         |        |       |                                     |        |        |        | 190     |
| (0xCD)  | UBRR1H   | -                                  | -       | -      | -     | USART1 Baud Rate Register High Byte |        |        |        | 194/207 |
| (0xCC)  | UBRR1L   | USART1 Baud Rate Register Low Byte |         |        |       |                                     |        |        |        | 194/207 |
| (0xCB)  | Reserved | -                                  | -       | -      | -     | -                                   | -      | -      | -      |         |
| (0xCA)  | UCSR1C   | UMSEL11                            | UMSEL10 | -      | -     | -                                   | UDORD1 | UCPHA1 | UCPOL1 | 192/206 |
| (0xC9)  | UCSR1B   | RXCIE1                             | TXCIE1  | UDRIE1 | RXEN1 | TXEN1                               | UCSZ12 | RXB81  | TXB81  | 191/205 |
| (0xC8)  | UCSR1A   | RXC1                               | TXC1    | UDRE1  | FE1   | DOR1                                | UPE1   | U2X1   | MPCM1  | 190/205 |
| (0xC7)  | Reserved | -                                  | -       | -      | -     | -                                   | -      | -      | -      |         |
| (0xC6)  | UDR0     | USART0 I/O Data Register           |         |        |       |                                     |        |        |        | 190     |
| (0xC5)  | UBRR0H   | -                                  | -       | -      | -     | USART0 Baud Rate Register High Byte |        |        |        | 194/207 |
| (0xC4)  | UBRR0L   | USART0 Baud Rate Register Low Byte |         |        |       |                                     |        |        |        | 194/207 |
| (0xC3)  | Reserved | -                                  | -       | -      | -     | -                                   | -      | -      | -      |         |
| (0xC2)  | UCSR0C   | UMSEL01                            | UMSEL00 | -      | -     | -                                   | UDORD0 | UCPHA0 | UCPOL0 | 192/206 |
| (0xC1)  | UCSR0B   | RXCIE0                             | TXCIE0  | UDRIE0 | RXEN0 | TXEN0                               | UCSZ02 | RXB80  | TXB80  | 191/205 |

| Address | Name     | Bit 7  | Bit 6  | Bit 5  | Bit 4  | Bit 3   | Bit 2   | Bit 1   | Bit 0   | Page    |
|---------|----------|--|--------|--------|--------|---------|---------|---------|---------|---------|
| (0xC0)  | UCSR0A   | RXC0   | TXC0   | UDRE0  | FE0    | DOR0    | UPE0    | U2X0    | MPCM0   | 190/205 |
| (0xBF)  | Reserved | -  | -      | -      | -      | -       | -       | -       | -       |         |
| (0xBE)  | Reserved | -  | -      | -      | -      | -       | -       | -       | -       |         |
| (0xBD)  | TWAMR    | TWAM6  | TWAM5  | TWAM4  | TWAM3  | TWAM2   | TWAM1   | TWAM0   | -       | 236     |
| (0xBC)  | TWCR     | TWINT  | TWEA   | TWSTA  | TWSTO  | TWWC    | TWEN    | -       | TWIE    | 233     |
| (0xBB)  | TWDR     | 2-wire Serial Interface Data Register                |        |        |        |         |         |         |         | 235     |
| (0xBA)  | TWAR     | TWA6   | TWA5   | TWA4   | TWA3   | TWA2    | TWA1    | TWA0    | TWGCE   | 236     |
| (0xB9)  | TWSR     | TWS7   | TWS6   | TWS5   | TWS4   | TWS3    | -       | TWSP1   | TWSP0   | 235     |
| (0xB8)  | TWBR     | 2-wire Serial Interface Bit Rate Register            |        |        |        |         |         |         |         | 233     |
| (0xB7)  | Reserved | -  | -      | -      | -      | -       | -       | -       | -       |         |
| (0xB6)  | ASSR     | -  | EXCLK  | AS2    | TCN2UB | OCR2AUB | OCR2BUB | TCR2AUB | TCR2BUB | 158     |
| (0xB5)  | Reserved | -  | -      | -      | -      | -       | -       | -       | -       |         |
| (0xB4)  | OCR2B    | Timer/Counter2 Output Compare Register B             |        |        |        |         |         |         |         | 158     |
| (0xB3)  | OCR2A    | Timer/Counter2 Output Compare Register A             |        |        |        |         |         |         |         | 158     |
| (0xB2)  | TCNT2    | Timer/Counter2 (8 Bit)                               |        |        |        |         |         |         |         | 157     |
| (0xB1)  | TCCR2B   | FOC2A  | FOC2B  | -      | -      | WGM22   | CS22    | CS21    | CS20    | 156     |
| (0xB0)  | TCCR2A   | COM2A1   | COM2A0 | COM2B1 | COM2B0 | -       | -       | WGM21   | WGM20   | 153     |
| (0xAF)  | Reserved | -  | -      | -      | -      | -       | -       | -       | -       |         |
| (0xAE)  | Reserved | -  | -      | -      | -      | -       | -       | -       | -       |         |
| (0xAD)  | Reserved | -  | -      | -      | -      | -       | -       | -       | -       |         |
| (0xAC)  | Reserved | -  | -      | -      | -      | -       | -       | -       | -       |         |
| (0xAB)  | Reserved | -  | -      | -      | -      | -       | -       | -       | -       |         |
| (0xAA)  | Reserved | -  | -      | -      | -      | -       | -       | -       | -       |         |
| (0xA9)  | Reserved | -  | -      | -      | -      | -       | -       | -       | -       |         |
| (0xA8)  | Reserved | -  | -      | -      | -      | -       | -       | -       | -       |         |
| (0xA7)  | Reserved | -  | -      | -      | -      | -       | -       | -       | -       |         |
| (0xA6)  | Reserved | -  | -      | -      | -      | -       | -       | -       | -       |         |
| (0xA5)  | Reserved | -  | -      | -      | -      | -       | -       | -       | -       |         |
| (0xA4)  | Reserved | -  | -      | -      | -      | -       | -       | -       | -       |         |
| (0xA3)  | Reserved | -  | -      | -      | -      | -       | -       | -       | -       |         |
| (0xA2)  | Reserved | -  | -      | -      | -      | -       | -       | -       | -       |         |
| (0xA1)  | Reserved | -  | -      | -      | -      | -       | -       | -       | -       |         |
| (0xA0)  | Reserved | -  | -      | -      | -      | -       | -       | -       | -       |         |
| (0x9F)  | Reserved | -  | -      | -      | -      | -       | -       | -       | -       |         |
| (0x9E)  | Reserved | -  | -      | -      | -      | -       | -       | -       | -       |         |
| (0x9D)  | Reserved | -  | -      | -      | -      | -       | -       | -       | -       |         |
| (0x9C)  | Reserved | -  | -      | -      | -      | -       | -       | -       | -       |         |
| (0x9B)  | Reserved | -  | -      | -      | -      | -       | -       | -       | -       |         |
| (0x9A)  | Reserved | -  | -      | -      | -      | -       | -       | -       | -       |         |
| (0x99)  | Reserved | -  | -      | -      | -      | -       | -       | -       | -       |         |
| (0x98)  | Reserved | -  | -      | -      | -      | -       | -       | -       | -       |         |
| (0x97)  | Reserved | -  | -      | -      | -      | -       | -       | -       | -       |         |
| (0x96)  | Reserved | -  | -      | -      | -      | -       | -       | -       | -       |         |
| (0x95)  | Reserved | -  | -      | -      | -      | -       | -       | -       | -       |         |
| (0x94)  | Reserved | -  | -      | -      | -      | -       | -       | -       | -       |         |
| (0x93)  | Reserved | -  | -      | -      | -      | -       | -       | -       | -       |         |
| (0x92)  | Reserved | -  | -      | -      | -      | -       | -       | -       | -       |         |
| (0x91)  | Reserved | -  | -      | -      | -      | -       | -       | -       | -       |         |
| (0x90)  | Reserved | -  | -      | -      | -      | -       | -       | -       | -       |         |
| (0x8F)  | Reserved | -  | -      | -      | -      | -       | -       | -       | -       |         |
| (0x8E)  | Reserved | -  | -      | -      | -      | -       | -       | -       | -       |         |
| (0x8D)  | Reserved | -  | -      | -      | -      | -       | -       | -       | -       |         |
| (0x8C)  | Reserved | -  | -      | -      | -      | -       | -       | -       | -       |         |
| (0x8B)  | OCR1BH   | Timer/Counter1 - Output Compare Register B High Byte |        |        |        |         |         |         |         | 137     |
| (0x8A)  | OCR1BL   | Timer/Counter1 - Output Compare Register B Low Byte  |        |        |        |         |         |         |         | 137     |
| (0x89)  | OCR1AH   | Timer/Counter1 - Output Compare Register A High Byte |        |        |        |         |         |         |         | 137     |
| (0x88)  | OCR1AL   | Timer/Counter1 - Output Compare Register A Low Byte  |        |        |        |         |         |         |         | 137     |
| (0x87)  | ICR1H    | Timer/Counter1 - Input Capture Register High Byte    |        |        |        |         |         |         |         | 138     |
| (0x86)  | ICR1L    | Timer/Counter1 - Input Capture Register Low Byte     |        |        |        |         |         |         |         | 138     |
| (0x85)  | TCNT1H   | Timer/Counter1 - Counter Register High Byte          |        |        |        |         |         |         |         | 137     |
| (0x84)  | TCNT1L   | Timer/Counter1 - Counter Register Low Byte           |        |        |        |         |         |         |         | 137     |
| (0x83)  | Reserved | -  | -      | -      | -      | -       | -       | -       | -       |         |
| (0x82)  | TCCR1C   | FOC1A  | FOC1B  | -      | -      | -       | -       | -       | -       | 136     |
| (0x81)  | TCCR1B   | ICNC1  | ICES1  | -      | WGM13  | WGM12   | CS12    | CS11    | CS10    | 135     |
| (0x80)  | TCCR1A   | COM1A1   | COM1A0 | COM1B1 | COM1B0 | -       | -       | WGM11   | WGM10   | 133     |
| (0x7F)  | DIDR1    | -  | -      | -      | -      | -       | -       | AIN1D   | AIN0D   | 240     |

| Address     | Name     | Bit 7                                    | Bit 6   | Bit 5   | Bit 4    | Bit 3                             | Bit 2   | Bit 1    | Bit 0    | Page   |
|-------------|----------|--|---------|---------|----------|-----------------------------------|---------|----------|----------|--------|
| (0x7E)      | DIDR0    | ADC7D                                    | ADC6D   | ADC5D   | ADC4D    | ADC3D                             | ADC2D   | ADC1D    | ADC0D    | 260    |
| (0x7D)      | Reserved | -  | -       | -       | -        | -                                 | -       | -        | -        |        |
| (0x7C)      | ADMUX    | REFS1                                    | REFS0   | ADLAR   | MUX4     | MUX3                              | MUX2    | MUX1     | MUX0     | 256    |
| (0x7B)      | ADCSRB   | -  | ACME    | -       | -        | -                                 | ADTS2   | ADTS1    | ADTS0    | 239    |
| (0x7A)      | ADCSRA   | ADEN                                     | ADSC    | ADATE   | ADIF     | ADIE                              | ADPS2   | ADPS1    | ADPS0    | 258    |
| (0x79)      | ADCH     | ADC Data Register High byte              |         |         |          |                                   |         |          |          | 259    |
| (0x78)      | ADCL     | ADC Data Register Low byte               |         |         |          |                                   |         |          |          | 259    |
| (0x77)      | Reserved | -  | -       | -       | -        | -                                 | -       | -        | -        |        |
| (0x76)      | Reserved | -  | -       | -       | -        | -                                 | -       | -        | -        |        |
| (0x75)      | Reserved | -  | -       | -       | -        | -                                 | -       | -        | -        |        |
| (0x74)      | Reserved | -  | -       | -       | -        | -                                 | -       | -        | -        |        |
| (0x73)      | PCMSK3   | PCINT31                                  | PCINT30 | PCINT29 | PCINT28  | PCINT27                           | PCINT26 | PCINT25  | PCINT24  | 71     |
| (0x72)      | Reserved | -  | -       | -       | -        | -                                 | -       | -        | -        |        |
| (0x71)      | Reserved | -  | -       | -       | -        | -                                 | -       | -        | -        |        |
| (0x70)      | TIMSK2   | -  | -       | -       | -        | -                                 | OCIE2B  | OCIE2A   | TOIE2    | 159    |
| (0x6F)      | TIMSK1   | -  | -       | ICIE1   | -        | -                                 | OCIE1B  | OCIE1A   | TOIE1    | 138    |
| (0x6E)      | TIMSK0   | -  | -       | -       | -        | -                                 | OCIE0B  | OCIE0A   | TOIE0    | 110    |
| (0x6D)      | PCMSK2   | PCINT23                                  | PCINT22 | PCINT21 | PCINT20  | PCINT19                           | PCINT18 | PCINT17  | PCINT16  | 71     |
| (0x6C)      | PCMSK1   | PCINT15                                  | PCINT14 | PCINT13 | PCINT12  | PCINT11                           | PCINT10 | PCINT9   | PCINT8   | 71     |
| (0x6B)      | PCMSK0   | PCINT7                                   | PCINT6  | PCINT5  | PCINT4   | PCINT3                            | PCINT2  | PCINT1   | PCINT0   | 72     |
| (0x6A)      | Reserved | -  | -       | -       | -        | -                                 | -       | -        | -        |        |
| (0x69)      | EICRA    | -  | -       | ISC21   | ISC20    | ISC11                             | ISC10   | ISC01    | ISC00    | 68     |
| (0x68)      | PCICR    | -  | -       | -       | -        | PCIE3                             | PCIE2   | PCIE1    | PCIE0    | 70     |
| (0x67)      | Reserved | -  | -       | -       | -        | -                                 | -       | -        | -        |        |
| (0x66)      | OSCCAL   | Oscillator Calibration Register          |         |         |          |                                   |         |          |          | 41     |
| (0x65)      | Reserved | -  | -       | -       | -        | -                                 | -       | -        | -        |        |
| (0x64)      | PRR      | PRTWI                                    | PRTIM2  | PRTIM0  | PRUSART1 | PRTIM1                            | PRSPI   | PRUSART0 | PRADC    | 49     |
| (0x63)      | Reserved | -  | -       | -       | -        | -                                 | -       | -        | -        |        |
| (0x62)      | Reserved | -  | -       | -       | -        | -                                 | -       | -        | -        |        |
| (0x61)      | CLKPR    | CLKPCE                                   | -       | -       | -        | CLKPS3                            | CLKPS2  | CLKPS1   | CLKPS0   | 41     |
| (0x60)      | WDTCR    | WDIF                                     | WDIE    | WDP3    | WDCE     | WDE                               | WDP2    | WDP1     | WDP0     | 60     |
| 0x3F (0x5F) | SREG     | I  | T       | H       | S        | V                                 | N       | Z        | C        | 11     |
| 0x3E (0x5E) | SPH      | SP15                                     | SP14    | SP13    | SP12     | SP11                              | SP10    | SP9      | SP8      | 12     |
| 0x3D (0x5D) | SPL      | SP7                                      | SP6     | SP5     | SP4      | SP3                               | SP2     | SP1      | SP0      | 12     |
| 0x3C (0x5C) | Reserved | -  | -       | -       | -        | -                                 | -       | -        | -        |        |
| 0x3B (0x5B) | Reserved | -  | -       | -       | -        | -                                 | -       | -        | -        |        |
| 0x3A (0x5A) | Reserved | -  | -       | -       | -        | -                                 | -       | -        | -        |        |
| 0x39 (0x59) | Reserved | -  | -       | -       | -        | -                                 | -       | -        | -        |        |
| 0x38 (0x58) | Reserved | -  | -       | -       | -        | -                                 | -       | -        | -        |        |
| 0x37 (0x57) | SPMCSR   | SPMIE                                    | RWWSB   | SIGRD   | RWWSRE   | BLBSET                            | PGWRT   | PGERS    | SPMEN    | 290    |
| 0x36 (0x56) | Reserved | -  | -       | -       | -        | -                                 | -       | -        | -        |        |
| 0x35 (0x55) | MCUCR    | JTD                                      | BODS    | BODSE   | PUD      | -                                 | -       | IVSEL    | IVCE     | 92/276 |
| 0x34 (0x54) | MCUSR    | -  | -       | -       | JTRF     | WDRF                              | BORF    | EXTRF    | PORF     | 59/276 |
| 0x33 (0x53) | SMCR     | -  | -       | -       | -        | SM2                               | SM1     | SM0      | SE       | 48     |
| 0x32 (0x52) | Reserved | -  | -       | -       | -        | -                                 | -       | -        | -        |        |
| 0x31 (0x51) | OCDR     | On-Chip Debug Register                   |         |         |          |                                   |         |          |          | 266    |
| 0x30 (0x50) | ACSR     | ACD                                      | ACBG    | ACO     | ACI      | ACIE                              | ACIC    | ACIS1    | ACIS0    | 258    |
| 0x2F (0x4F) | Reserved | -  | -       | -       | -        | -                                 | -       | -        | -        |        |
| 0x2E (0x4E) | SPDR     | SPI 0 Data Register                      |         |         |          |                                   |         |          |          | 171    |
| 0x2D (0x4D) | SPSR     | SPIF0                                    | WCOL0   | -       | -        | -                                 | -       | -        | SPI2X0   | 170    |
| 0x2C (0x4C) | SPCR     | SPIE0                                    | SPE0    | DORD0   | MSTR0    | CPOL0                             | CPHA0   | SPR01    | SPR00    | 169    |
| 0x2B (0x4B) | GPOR2    | General Purpose I/O Register 2           |         |         |          |                                   |         |          |          | 29     |
| 0x2A (0x4A) | GPOR1    | General Purpose I/O Register 1           |         |         |          |                                   |         |          |          | 29     |
| 0x29 (0x49) | Reserved | -  | -       | -       | -        | -                                 | -       | -        | -        |        |
| 0x28 (0x48) | OCR0B    | Timer/Counter0 Output Compare Register B |         |         |          |                                   |         |          |          | 110    |
| 0x27 (0x47) | OCR0A    | Timer/Counter0 Output Compare Register A |         |         |          |                                   |         |          |          | 109    |
| 0x26 (0x46) | TCNT0    | Timer/Counter0 (8 Bit)                   |         |         |          |                                   |         |          |          | 109    |
| 0x25 (0x45) | TCCR0B   | FOC0A                                    | FOC0B   | -       | -        | WGM02                             | CS02    | CS01     | CS00     | 108    |
| 0x24 (0x44) | TCCR0A   | COM0A1                                   | COM0A0  | COM0B1  | COM0B0   | -                                 | -       | WGM01    | WGM00    | 110    |
| 0x23 (0x43) | GTCCR    | TSM                                      | -       | -       | -        | -                                 | -       | PSRASY   | PSR5SYNC | 160    |
| 0x22 (0x42) | EEARH    | -  | -       | -       | -        | EEPROM Address Register High Byte |         |          |          | 24     |
| 0x21 (0x41) | EEARL    | EEPROM Address Register Low Byte         |         |         |          |                                   |         |          |          | 24     |
| 0x20 (0x40) | EEDR     | EEPROM Data Register                     |         |         |          |                                   |         |          |          | 24     |
| 0x1F (0x3F) | EEDR     | -  | -       | EEDR1   | EEDR0    | EEDR2                             | EEDR3   | EEDR4    | EEDR5    | 24     |
| 0x1E (0x3E) | GPOR0    | General Purpose I/O Register 0           |         |         |          |                                   |         |          |          | 29     |
| 0x1D (0x3D) | EIMSK    | -  | -       | -       | -        | -                                 | INT2    | INT1     | INT0     | 69     |

| Address     | Name     | Bit 7  | Bit 6  | Bit 5  | Bit 4  | Bit 3  | Bit 2  | Bit 1  | Bit 0  | Page |
|-------------|----------|--------|--------|--------|--------|--------|--------|--------|--------|------|
| 0x1C (0x3C) | EIFR     | -      | -      | -      | -      | -      | INTF2  | INTF1  | INTF0  | 69   |
| 0x1B (0x3B) | PCIFR    | -      | -      | -      | -      | PCIF3  | PCIF2  | PCIF1  | PCIF0  | 70   |
| 0x1A (0x3A) | Reserved | -      | -      | -      | -      | -      | -      | -      | -      |      |
| 0x19 (0x39) | Reserved | -      | -      | -      | -      | -      | -      | -      | -      |      |
| 0x18 (0x38) | Reserved | -      | -      | -      | -      | -      | -      | -      | -      |      |
| 0x17 (0x37) | TIFR2    | -      | -      | -      | -      | -      | OCF2B  | OCF2A  | TOV2   | 160  |
| 0x16 (0x36) | TIFR1    | -      | -      | ICF1   | -      | -      | OCF1B  | OCF1A  | TOV1   | 139  |
| 0x15 (0x35) | TIFR0    | -      | -      | -      | -      | -      | OCF0B  | OCF0A  | TOV0   | 110  |
| 0x14 (0x34) | Reserved | -      | -      | -      | -      | -      | -      | -      | -      |      |
| 0x13 (0x33) | Reserved | -      | -      | -      | -      | -      | -      | -      | -      |      |
| 0x12 (0x32) | Reserved | -      | -      | -      | -      | -      | -      | -      | -      |      |
| 0x11 (0x31) | Reserved | -      | -      | -      | -      | -      | -      | -      | -      |      |
| 0x10 (0x30) | Reserved | -      | -      | -      | -      | -      | -      | -      | -      |      |
| 0x0F (0x2F) | Reserved | -      | -      | -      | -      | -      | -      | -      | -      |      |
| 0x0E (0x2E) | Reserved | -      | -      | -      | -      | -      | -      | -      | -      |      |
| 0x0D (0x2D) | Reserved | -      | -      | -      | -      | -      | -      | -      | -      |      |
| 0x0C (0x2C) | Reserved | -      | -      | -      | -      | -      | -      | -      | -      |      |
| 0x0B (0x2B) | PORTD    | PORTD7 | PORTD6 | PORTD5 | PORTD4 | PORTD3 | PORTD2 | PORTD1 | PORTD0 | 93   |
| 0x0A (0x2A) | DDRD     | DDD7   | DDD6   | DDD5   | DDD4   | DDD3   | DDD2   | DDD1   | DDD0   | 93   |
| 0x09 (0x29) | PIND     | PIND7  | PIND6  | PIND5  | PIND4  | PIND3  | PIND2  | PIND1  | PIND0  | 93   |
| 0x08 (0x28) | PORTC    | PORTC7 | PORTC6 | PORTC5 | PORTC4 | PORTC3 | PORTC2 | PORTC1 | PORTC0 | 93   |
| 0x07 (0x27) | DDRC     | DDC7   | DDC6   | DDC5   | DDC4   | DDC3   | DDC2   | DDC1   | DDC0   | 93   |
| 0x06 (0x26) | PINC     | PINC7  | PINC6  | PINC5  | PINC4  | PINC3  | PINC2  | PINC1  | PINC0  | 93   |
| 0x05 (0x25) | PORTB    | PORTB7 | PORTB6 | PORTB5 | PORTB4 | PORTB3 | PORTB2 | PORTB1 | PORTB0 | 92   |
| 0x04 (0x24) | DDRB     | DDB7   | DDB6   | DDB5   | DDB4   | DDB3   | DDB2   | DDB1   | DDB0   | 92   |
| 0x03 (0x23) | PINB     | PINB7  | PINB6  | PINB5  | PINB4  | PINB3  | PINB2  | PINB1  | PINB0  | 92   |
| 0x02 (0x22) | PORTA    | PORTA7 | PORTA6 | PORTA5 | PORTA4 | PORTA3 | PORTA2 | PORTA1 | PORTA0 | 92   |
| 0x01 (0x21) | DDRA     | DDA7   | DDA6   | DDA5   | DDA4   | DDA3   | DDA2   | DDA1   | DDA0   | 92   |
| 0x00 (0x20) | PINA     | PINA7  | PINA6  | PINA5  | PINA4  | PINA3  | PINA2  | PINA1  | PINA0  | 92   |

- Notes:
- For compatibility with future devices, reserved bits should be written to zero if accessed. Reserved I/O memory addresses should never be written.
  - I/O registers within the address range \$00 - \$1F are directly bit-accessible using the SBI and CBI instructions. In these registers, the value of single bits can be checked by using the SBIS and SBIC instructions.
  - Some of the status flags are cleared by writing a logical one to them. Note that the CBI and SBI instructions will operate on all bits in the I/O register, writing a one back into any flag read as set, thus clearing the flag. The CBI and SBI instructions work with registers 0x00 to 0x1F only.
  - When using the I/O specific commands IN and OUT, the I/O addresses \$00 - \$3F must be used. When addressing I/O registers as data space using LD and ST instructions, \$20 must be added to these addresses. The ATmega164PA/324PA/644PA is a complex microcontroller with more peripheral units than can be supported within the 64 location reserved in Opcode for the IN and OUT instructions. For the Extended I/O space from \$60 - \$FF, only the ST/STS/STD and LD/LDS/LDD instructions can be used.

## 7. Instruction Set Summary

| Mnemonics                                | Operands | Description                              | Operation   | Flags         | #Clocks |
|--|----------|--|---|---------------|---------|
| <b>ARITHMETIC AND LOGIC INSTRUCTIONS</b> |          |  |   |               |         |
| ADD                                      | Rd, Rr   | Add two Registers                        | $Rd \leftarrow Rd + Rr$                               | Z,C,N,V,H     | 1       |
| ADC                                      | Rd, Rr   | Add with Carry two Registers             | $Rd \leftarrow Rd + Rr + C$                           | Z,C,N,V,H     | 1       |
| ADIW                                     | RdI,K    | Add Immediate to Word                    | $Rdh:Rdl \leftarrow Rdh:Rdl + K$                      | Z,C,N,V,S     | 2       |
| SUB                                      | Rd, Rr   | Subtract two Registers                   | $Rd \leftarrow Rd - Rr$                               | Z,C,N,V,H     | 1       |
| SUBI                                     | Rd, K    | Subtract Constant from Register          | $Rd \leftarrow Rd - K$                                | Z,C,N,V,H     | 1       |
| SBC                                      | Rd, Rr   | Subtract with Carry two Registers        | $Rd \leftarrow Rd - Rr - C$                           | Z,C,N,V,H     | 1       |
| SBCI                                     | Rd, K    | Subtract with Carry Constant from Reg.   | $Rd \leftarrow Rd - K - C$                            | Z,C,N,V,H     | 1       |
| SBIW                                     | RdI,K    | Subtract Immediate from Word             | $Rdh:Rdl \leftarrow Rdh:Rdl - K$                      | Z,C,N,V,S     | 2       |
| AND                                      | Rd, Rr   | Logical AND Registers                    | $Rd \leftarrow Rd \cdot Rr$                           | Z,N,V         | 1       |
| ANDI                                     | Rd, K    | Logical AND Register and Constant        | $Rd \leftarrow Rd \cdot K$                            | Z,N,V         | 1       |
| OR                                       | Rd, Rr   | Logical OR Registers                     | $Rd \leftarrow Rd \vee Rr$                            | Z,N,V         | 1       |
| ORI                                      | Rd, K    | Logical OR Register and Constant         | $Rd \leftarrow Rd \vee K$                             | Z,N,V         | 1       |
| EOR                                      | Rd, Rr   | Exclusive OR Registers                   | $Rd \leftarrow Rd \oplus Rr$                          | Z,N,V         | 1       |
| COM                                      | Rd       | One's Complement                         | $Rd \leftarrow 0xFF - Rd$                             | Z,C,N,V       | 1       |
| NEG                                      | Rd       | Two's Complement                         | $Rd \leftarrow 0x00 - Rd$                             | Z,C,N,V,H     | 1       |
| SBR                                      | Rd,K     | Set Bit(s) in Register                   | $Rd \leftarrow Rd \vee K$                             | Z,N,V         | 1       |
| CBR                                      | Rd,K     | Clear Bit(s) in Register                 | $Rd \leftarrow Rd \cdot (0xFF - K)$                   | Z,N,V         | 1       |
| INC                                      | Rd       | Increment                                | $Rd \leftarrow Rd + 1$                                | Z,N,V         | 1       |
| DEC                                      | Rd       | Decrement                                | $Rd \leftarrow Rd - 1$                                | Z,N,V         | 1       |
| TST                                      | Rd       | Test for Zero or Minus                   | $Rd \leftarrow Rd \cdot Rd$                           | Z,N,V         | 1       |
| CLR                                      | Rd       | Clear Register                           | $Rd \leftarrow Rd \oplus Rd$                          | Z,N,V         | 1       |
| SER                                      | Rd       | Set Register                             | $Rd \leftarrow 0xFF$                                  | None          | 1       |
| MUL                                      | Rd, Rr   | Multiply Unsigned                        | $R1:R0 \leftarrow Rd \times Rr$                       | Z,C           | 2       |
| MULS                                     | Rd, Rr   | Multiply Signed                          | $R1:R0 \leftarrow Rd \times Rr$                       | Z,C           | 2       |
| MULSU                                    | Rd, Rr   | Multiply Signed with Unsigned            | $R1:R0 \leftarrow Rd \times Rr$                       | Z,C           | 2       |
| FMUL                                     | Rd, Rr   | Fractional Multiply Unsigned             | $R1:R0 \leftarrow (Rd \times Rr) \lll 1$              | Z,C           | 2       |
| FMULS                                    | Rd, Rr   | Fractional Multiply Signed               | $R1:R0 \leftarrow (Rd \times Rr) \lll 1$              | Z,C           | 2       |
| FMULSU                                   | Rd, Rr   | Fractional Multiply Signed with Unsigned | $R1:R0 \leftarrow (Rd \times Rr) \lll 1$              | Z,C           | 2       |
| <b>BRANCH INSTRUCTIONS</b>               |          |  |   |               |         |
| RJMP                                     | k        | Relative Jump                            | $PC \leftarrow PC + k + 1$                            | None          | 2       |
| IJMP                                     |          | Indirect Jump to (Z)                     | $PC \leftarrow Z$                                     | None          | 2       |
| JMP                                      | k        | Direct Jump                              | $PC \leftarrow k$                                     | None          | 3       |
| RCALL                                    | k        | Relative Subroutine Call                 | $PC \leftarrow PC + k + 1$                            | None          | 4       |
| ICALL                                    |          | Indirect Call to (Z)                     | $PC \leftarrow Z$                                     | None          | 4       |
| CALL                                     | k        | Direct Subroutine Call                   | $PC \leftarrow k$                                     | None          | 5       |
| RET                                      |          | Subroutine Return                        | $PC \leftarrow STACK$                                 | None          | 5       |
| RETI                                     |          | Interrupt Return                         | $PC \leftarrow STACK$                                 | I             | 5       |
| CPSE                                     | Rd,Rr    | Compare, Skip if Equal                   | if (Rd = Rr) $PC \leftarrow PC + 2$ or 3              | None          | 1/2/3   |
| CP                                       | Rd,Rr    | Compare                                  | $Rd - Rr$   | Z, N, V, C, H | 1       |
| CPC                                      | Rd,Rr    | Compare with Carry                       | $Rd - Rr - C$   | Z, N, V, C, H | 1       |
| CPI                                      | Rd,K     | Compare Register with Immediate          | $Rd - K$  | Z, N, V, C, H | 1       |
| SBRC                                     | Rr, b    | Skip if Bit in Register Cleared          | if (Rr(b)=0) $PC \leftarrow PC + 2$ or 3              | None          | 1/2/3   |
| SBRS                                     | Rr, b    | Skip if Bit in Register is Set           | if (Rr(b)=1) $PC \leftarrow PC + 2$ or 3              | None          | 1/2/3   |
| SBIC                                     | P, b     | Skip if Bit in I/O Register Cleared      | if (P(b)=0) $PC \leftarrow PC + 2$ or 3               | None          | 1/2/3   |
| SBIS                                     | P, b     | Skip if Bit in I/O Register is Set       | if (P(b)=1) $PC \leftarrow PC + 2$ or 3               | None          | 1/2/3   |
| BRBS                                     | s, k     | Branch if Status Flag Set                | if (SREG(s) = 1) then $PC \leftarrow PC + k + 1$      | None          | 1/2     |
| BRBC                                     | s, k     | Branch if Status Flag Cleared            | if (SREG(s) = 0) then $PC \leftarrow PC + k + 1$      | None          | 1/2     |
| BREQ                                     | k        | Branch if Equal                          | if (Z = 1) then $PC \leftarrow PC + k + 1$            | None          | 1/2     |
| BRNE                                     | k        | Branch if Not Equal                      | if (Z = 0) then $PC \leftarrow PC + k + 1$            | None          | 1/2     |
| BRCS                                     | k        | Branch if Carry Set                      | if (C = 1) then $PC \leftarrow PC + k + 1$            | None          | 1/2     |
| BRCC                                     | k        | Branch if Carry Cleared                  | if (C = 0) then $PC \leftarrow PC + k + 1$            | None          | 1/2     |
| BRSH                                     | k        | Branch if Same or Higher                 | if (C = 0) then $PC \leftarrow PC + k + 1$            | None          | 1/2     |
| BRLO                                     | k        | Branch if Lower                          | if (C = 1) then $PC \leftarrow PC + k + 1$            | None          | 1/2     |
| BRMI                                     | k        | Branch if Minus                          | if (N = 1) then $PC \leftarrow PC + k + 1$            | None          | 1/2     |
| BRPL                                     | k        | Branch if Plus                           | if (N = 0) then $PC \leftarrow PC + k + 1$            | None          | 1/2     |
| BRGE                                     | k        | Branch if Greater or Equal, Signed       | if (N $\oplus$ V = 0) then $PC \leftarrow PC + k + 1$ | None          | 1/2     |
| BRLT                                     | k        | Branch if Less Than Zero, Signed         | if (N $\oplus$ V = 1) then $PC \leftarrow PC + k + 1$ | None          | 1/2     |
| BRHS                                     | k        | Branch if Half Carry Flag Set            | if (H = 1) then $PC \leftarrow PC + k + 1$            | None          | 1/2     |
| BRHC                                     | k        | Branch if Half Carry Flag Cleared        | if (H = 0) then $PC \leftarrow PC + k + 1$            | None          | 1/2     |
| BRTS                                     | k        | Branch if T Flag Set                     | if (T = 1) then $PC \leftarrow PC + k + 1$            | None          | 1/2     |
| BRTC                                     | k        | Branch if T Flag Cleared                 | if (T = 0) then $PC \leftarrow PC + k + 1$            | None          | 1/2     |
| BRVS                                     | k        | Branch if Overflow Flag is Set           | if (V = 1) then $PC \leftarrow PC + k + 1$            | None          | 1/2     |

| Mnemonics                            | Operands | Description                        | Operation                                | Flags   | #Clocks |
|--------------------------------------|----------|------------------------------------|--|---------|---------|
| BRVC                                 | k        | Branch if Overflow Flag is Cleared | if (V = 0) then PC ← PC + k + 1          | None    | 1/2     |
| BRIE                                 | k        | Branch if Interrupt Enabled        | if (I = 1) then PC ← PC + k + 1          | None    | 1/2     |
| BRID                                 | k        | Branch if Interrupt Disabled       | if (I = 0) then PC ← PC + k + 1          | None    | 1/2     |
| <b>BIT AND BIT-TEST INSTRUCTIONS</b> |          |                                    |  |         |         |
| SBI                                  | P,b      | Set Bit in I/O Register            | I/O(P,b) ← 1                             | None    | 2       |
| CBI                                  | P,b      | Clear Bit in I/O Register          | I/O(P,b) ← 0                             | None    | 2       |
| LSL                                  | Rd       | Logical Shift Left                 | Rd(n+1) ← Rd(n), Rd(0) ← 0               | Z,C,N,V | 1       |
| LSR                                  | Rd       | Logical Shift Right                | Rd(n) ← Rd(n+1), Rd(7) ← 0               | Z,C,N,V | 1       |
| ROL                                  | Rd       | Rotate Left Through Carry          | Rd(0) ← C, Rd(n+1) ← Rd(n), C ← Rd(7)    | Z,C,N,V | 1       |
| ROR                                  | Rd       | Rotate Right Through Carry         | Rd(7) ← C, Rd(n) ← Rd(n+1), C ← Rd(0)    | Z,C,N,V | 1       |
| ASR                                  | Rd       | Arithmetic Shift Right             | Rd(n) ← Rd(n+1), n=0..6                  | Z,C,N,V | 1       |
| SWAP                                 | Rd       | Swap Nibbles                       | Rd(3..0) ← Rd(7..4), Rd(7..4) ← Rd(3..0) | None    | 1       |
| BSET                                 | s        | Flag Set                           | SREG(s) ← 1                              | SREG(s) | 1       |
| BCLR                                 | s        | Flag Clear                         | SREG(s) ← 0                              | SREG(s) | 1       |
| BST                                  | Rr, b    | Bit Store from Register to T       | T ← Rr(b)                                | T       | 1       |
| BLD                                  | Rd, b    | Bit load from T to Register        | Rd(b) ← T                                | None    | 1       |
| SEC                                  |          | Set Carry                          | C ← 1                                    | C       | 1       |
| CLC                                  |          | Clear Carry                        | C ← 0                                    | C       | 1       |
| SEN                                  |          | Set Negative Flag                  | N ← 1                                    | N       | 1       |
| CLN                                  |          | Clear Negative Flag                | N ← 0                                    | N       | 1       |
| SEZ                                  |          | Set Zero Flag                      | Z ← 1                                    | Z       | 1       |
| CLZ                                  |          | Clear Zero Flag                    | Z ← 0                                    | Z       | 1       |
| SEI                                  |          | Global Interrupt Enable            | I ← 1                                    | I       | 1       |
| CLI                                  |          | Global Interrupt Disable           | I ← 0                                    | I       | 1       |
| SES                                  |          | Set Signed Test Flag               | S ← 1                                    | S       | 1       |
| CLS                                  |          | Clear Signed Test Flag             | S ← 0                                    | S       | 1       |
| SEV                                  |          | Set Twos Complement Overflow.      | V ← 1                                    | V       | 1       |
| CLV                                  |          | Clear Twos Complement Overflow     | V ← 0                                    | V       | 1       |
| SET                                  |          | Set T in SREG                      | T ← 1                                    | T       | 1       |
| CLT                                  |          | Clear T in SREG                    | T ← 0                                    | T       | 1       |
| SEH                                  |          | Set Half Carry Flag in SREG        | H ← 1                                    | H       | 1       |
| CLH                                  |          | Clear Half Carry Flag in SREG      | H ← 0                                    | H       | 1       |
| <b>DATA TRANSFER INSTRUCTIONS</b>    |          |                                    |  |         |         |
| MOV                                  | Rd, Rr   | Move Between Registers             | Rd ← Rr                                  | None    | 1       |
| MOVW                                 | Rd, Rr   | Copy Register Word                 | Rd+1:Rd ← Rr+1:Rr                        | None    | 1       |
| LDI                                  | Rd, K    | Load Immediate                     | Rd ← K                                   | None    | 1       |
| LD                                   | Rd, X    | Load Indirect                      | Rd ← (X)                                 | None    | 2       |
| LD                                   | Rd, X+   | Load Indirect and Post-Inc.        | Rd ← (X), X ← X + 1                      | None    | 2       |
| LD                                   | Rd, -X   | Load Indirect and Pre-Dec.         | X ← X - 1, Rd ← (X)                      | None    | 2       |
| LD                                   | Rd, Y    | Load Indirect                      | Rd ← (Y)                                 | None    | 2       |
| LD                                   | Rd, Y+   | Load Indirect and Post-Inc.        | Rd ← (Y), Y ← Y + 1                      | None    | 2       |
| LD                                   | Rd, -Y   | Load Indirect and Pre-Dec.         | Y ← Y - 1, Rd ← (Y)                      | None    | 2       |
| LDD                                  | Rd, Y+q  | Load Indirect with Displacement    | Rd ← (Y + q)                             | None    | 2       |
| LD                                   | Rd, Z    | Load Indirect                      | Rd ← (Z)                                 | None    | 2       |
| LD                                   | Rd, Z+   | Load Indirect and Post-Inc.        | Rd ← (Z), Z ← Z+1                        | None    | 2       |
| LD                                   | Rd, -Z   | Load Indirect and Pre-Dec.         | Z ← Z - 1, Rd ← (Z)                      | None    | 2       |
| LDD                                  | Rd, Z+q  | Load Indirect with Displacement    | Rd ← (Z + q)                             | None    | 2       |
| LDS                                  | Rd, k    | Load Direct from SRAM              | Rd ← (k)                                 | None    | 2       |
| ST                                   | X, Rr    | Store Indirect                     | (X) ← Rr                                 | None    | 2       |
| ST                                   | X+, Rr   | Store Indirect and Post-Inc.       | (X) ← Rr, X ← X + 1                      | None    | 2       |
| ST                                   | -X, Rr   | Store Indirect and Pre-Dec.        | X ← X - 1, (X) ← Rr                      | None    | 2       |
| ST                                   | Y, Rr    | Store Indirect                     | (Y) ← Rr                                 | None    | 2       |
| ST                                   | Y+, Rr   | Store Indirect and Post-Inc.       | (Y) ← Rr, Y ← Y + 1                      | None    | 2       |
| ST                                   | -Y, Rr   | Store Indirect and Pre-Dec.        | Y ← Y - 1, (Y) ← Rr                      | None    | 2       |
| STD                                  | Y+q, Rr  | Store Indirect with Displacement   | (Y + q) ← Rr                             | None    | 2       |
| ST                                   | Z, Rr    | Store Indirect                     | (Z) ← Rr                                 | None    | 2       |
| ST                                   | Z+, Rr   | Store Indirect and Post-Inc.       | (Z) ← Rr, Z ← Z + 1                      | None    | 2       |
| ST                                   | -Z, Rr   | Store Indirect and Pre-Dec.        | Z ← Z - 1, (Z) ← Rr                      | None    | 2       |
| STD                                  | Z+q, Rr  | Store Indirect with Displacement   | (Z + q) ← Rr                             | None    | 2       |
| STS                                  | k, Rr    | Store Direct to SRAM               | (k) ← Rr                                 | None    | 2       |
| LPM                                  |          | Load Program Memory                | R0 ← (Z)                                 | None    | 3       |
| LPM                                  | Rd, Z    | Load Program Memory                | Rd ← (Z)                                 | None    | 3       |
| LPM                                  | Rd, Z+   | Load Program Memory and Post-Inc   | Rd ← (Z), Z ← Z+1                        | None    | 3       |
| SPM                                  |          | Store Program Memory               | (Z) ← R1:R0                              | None    | -       |
| IN                                   | Rd, P    | In Port                            | Rd ← P                                   | None    | 1       |
| OUT                                  | P, Rr    | Out Port                           | P ← Rr                                   | None    | 1       |



| Mnemonics                       | Operands | Description             | Operation                                | Flags | #Clocks |
|---------------------------------|----------|-------------------------|--|-------|---------|
| PUSH                            | Rr       | Push Register on Stack  | STACK ← Rr                               | None  | 2       |
| POP                             | Rd       | Pop Register from Stack | Rd ← STACK                               | None  | 2       |
| <b>MCU CONTROL INSTRUCTIONS</b> |          |                         |  |       |         |
| NOP                             |          | No Operation            |  | None  | 1       |
| SLEEP                           |          | Sleep                   | (see specific descr. for Sleep function) | None  | 1       |
| WDR                             |          | Watchdog Reset          | (see specific descr. for WDR/timer)      | None  | 1       |
| BREAK                           |          | Break                   | For On-chip Debug Only                   | None  | N/A     |





## 8. Ordering Information

### 8.1 ATmega164PA

| Speed (MHz) <sup>(3)</sup> | Power Supply | Ordering Code <sup>(2)</sup>   | Package <sup>(1)</sup>              | Operational Range             |
|----------------------------|--------------|--|-------------------------------------|-------------------------------|
| 20                         | 1.8 - 5.5V   | ATmega164PA-AU<br>ATmega164PA-PU<br>ATmega164PA-MU<br>ATmega164PA-MCH <sup>(4)</sup><br>ATmega164PA-CU | 44A<br>40P6<br>44M1<br>44MC<br>49C2 | Industrial<br>(-40°C to 85°C) |

- Notes:
1. This device can also be supplied in wafer form. Please contact your local Atmel sales office for detailed ordering information and minimum quantities.
  2. Pb-free packaging, complies to the European Directive for Restriction of Hazardous Substances (RoHS directive). Also Halide free and fully Green.
  3. For Speed vs.  $V_{CC}$  see "[Speed Grades](#)" on page 328.
  4. NiPdAu Lead Finish.

| Package Type |  |
|--------------|--|
| 44A          | 44-lead, Thin (1.0 mm) Plastic Gull Wing Quad Flat Package (TQFP)  |
| 40P6         | 40-pin, 0.600" Wide, Plastic Dual Inline Package (PDIP)  |
| 44M1         | 44-pad, 7 x 7 x 1.0 mm body, lead pitch 0.50 mm, Thermally Enhanced Plastic Very Thin Quad Flat No-Lead (VQFN) |
| 44MC         | 44-lead (2-row Staggered), 5 x 5 x 1.0 mm body, 2.60 x 2.60 mm Exposed Pad, Quad Flat No-Lead Package (QFN)    |
| 49C2         | 49-ball, (7 x 7 Array) 0.65 mm Pitch, 5 x 5 x 1 mm, Very Thin, Fine-Pitch Ball Grid Array Package (VFBGA)      |



## 8.2 ATmega324PA

| Speed (MHz) <sup>(3)</sup> | Power Supply | Ordering Code <sup>(2)</sup>   | Package <sup>(1)</sup>              | Operational Range             |
|----------------------------|--------------|--|-------------------------------------|-------------------------------|
| 20                         | 1.8 - 5.5V   | ATmega324PA-AU<br>ATmega324PA-PU<br>ATmega324PA-MU<br>ATmega324PA-MCH <sup>(4)</sup><br>ATmega324PA-CU | 44A<br>40P6<br>44M1<br>44MC<br>49C2 | Industrial<br>(-40°C to 85°C) |

- Notes:
1. This device can also be supplied in wafer form. Please contact your local Atmel sales office for detailed ordering information and minimum quantities.
  2. Pb-free packaging, complies to the European Directive for Restriction of Hazardous Substances (RoHS directive). Also Halide free and fully Green.
  3. For Speed vs.  $V_{CC}$  see ["Speed Grades" on page 328](#).
  4. NiPdAu Lead Finish.

| Package Type |  |
|--------------|--|
| 44A          | 44-lead, Thin (1.0 mm) Plastic Gull Wing Quad Flat Package (TQFP)  |
| 40P6         | 40-pin, 0.600" Wide, Plastic Dual Inline Package (PDIP)  |
| 44M1         | 44-pad, 7 x 7 x 1.0 mm body, lead pitch 0.50 mm, Thermally Enhanced Plastic Very Thin Quad Flat No-Lead (VQFN) |
| 44MC         | 44-lead (2-row Staggered), 5 x 5 x 1.0 mm body, 2.60 x 2.60 mm Exposed Pad, Quad Flat No-Lead Package (QFN)    |
| 49C2         | 49-ball, (7 x 7 Array) 0.65 mm Pitch, 5 x 5 x 1 mm, Very Thin, Fine-Pitch Ball Grid Array Package (VFPGA)      |

## 8.3 ATmega644PA

| Speed (MHz) <sup>(3)</sup> | Power Supply | Ordering Code <sup>(2)</sup>                       | Package <sup>(1)</sup> | Operational Range             |
|----------------------------|--------------|--|------------------------|-------------------------------|
| 20                         | 1.8 - 5.5V   | ATmega644PA-AU<br>ATmega644PA-PU<br>ATmega644PA-MU | 44A<br>40P6<br>44M1    | Industrial<br>(-40°C to 85°C) |

- Notes:
1. This device can also be supplied in wafer form. Please contact your local Atmel sales office for detailed ordering information and minimum quantities.
  2. Pb-free packaging, complies to the European Directive for Restriction of Hazardous Substances (RoHS directive). Also Halide free and fully Green.
  3. For Speed vs.  $V_{CC}$  see "[Speed Grades](#)" on page 328.

| Package Type |  |
|--------------|--|
| 44A          | 44-lead, Thin (1.0 mm) Plastic Gull Wing Quad Flat Package (TQFP)  |
| 40P6         | 40-pin, 0.600" Wide, Plastic Dual Inline Package (PDIP)  |
| 44M1         | 44-pad, 7 x 7 x 1.0 mm body, lead pitch 0.50 mm, Thermally Enhanced Plastic Very Thin Quad Flat No-Lead (VQFN) |

## 9. Packaging Information

### 9.1 44A

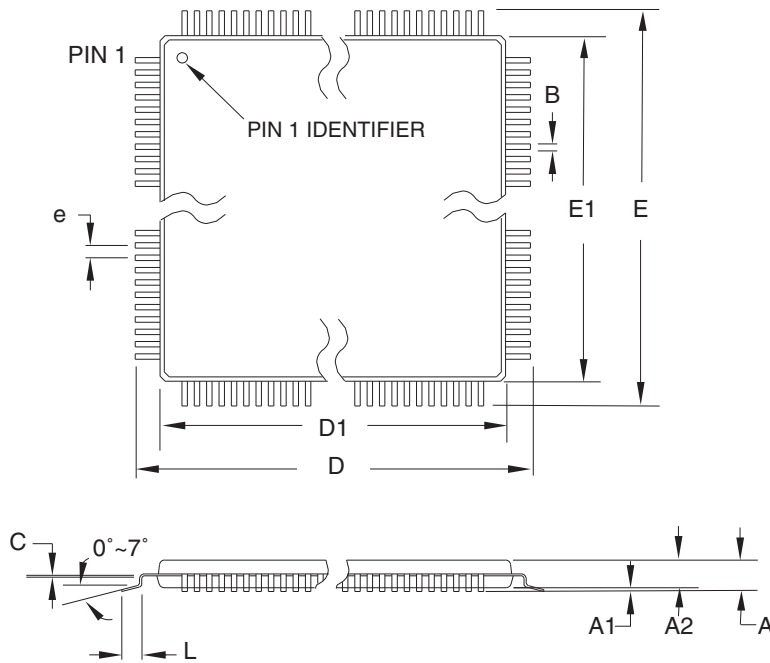

**COMMON DIMENSIONS**  
(Unit of Measure = mm)

| SYMBOL | MIN      | NOM   | MAX   | NOTE   |
|--------|----------|-------|-------|--------|
| A      | –        | –     | 1.20  |        |
| A1     | 0.05     | –     | 0.15  |        |
| A2     | 0.95     | 1.00  | 1.05  |        |
| D      | 11.75    | 12.00 | 12.25 |        |
| D1     | 9.90     | 10.00 | 10.10 | Note 2 |
| E      | 11.75    | 12.00 | 12.25 |        |
| E1     | 9.90     | 10.00 | 10.10 | Note 2 |
| B      | 0.30     | –     | 0.45  |        |
| C      | 0.09     | –     | 0.20  |        |
| L      | 0.45     | –     | 0.75  |        |
| e      | 0.80 TYP |       |       |        |

- Notes:
1. This package conforms to JEDEC reference MS-026, Variation ACB.
  2. Dimensions D1 and E1 do not include mold protrusion. Allowable protrusion is 0.25 mm per side. Dimensions D1 and E1 are maximum plastic body size dimensions including mold mismatch.
  3. Lead coplanarity is 0.10 mm maximum.

10/5/2001



2325 Orchard Parkway  
San Jose, CA 95131

**TITLE**

**44A**, 44-lead, 10 x 10 mm Body Size, 1.0 mm Body Thickness,  
0.8 mm Lead Pitch, Thin Profile Plastic Quad Flat Package (TQFP)

**DRAWING NO.**

44A

**REV.**

B

## 9.2 40P6

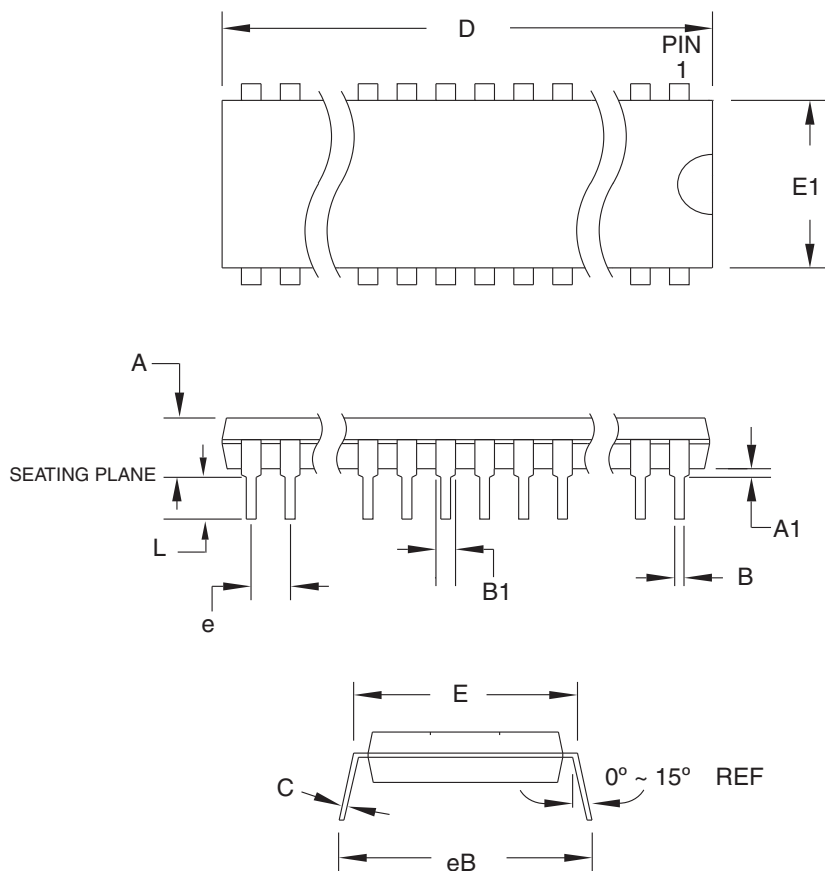

**COMMON DIMENSIONS**  
(Unit of Measure = mm)

| SYMBOL | MIN       | NOM | MAX    | NOTE   |
|--------|-----------|-----|--------|--------|
| A      | –         | –   | 4.826  |        |
| A1     | 0.381     | –   | –      |        |
| D      | 52.070    | –   | 52.578 | Note 2 |
| E      | 15.240    | –   | 15.875 |        |
| E1     | 13.462    | –   | 13.970 | Note 2 |
| B      | 0.356     | –   | 0.559  |        |
| B1     | 1.041     | –   | 1.651  |        |
| L      | 3.048     | –   | 3.556  |        |
| C      | 0.203     | –   | 0.381  |        |
| eB     | 15.494    | –   | 17.526 |        |
| e      | 2.540 TYP |     |        |        |

- Notes: 1. This package conforms to JEDEC reference MS-011, Variation AC.  
2. Dimensions D and E1 do not include mold Flash or Protrusion. Mold Flash or Protrusion shall not exceed 0.25 mm (0.010").

09/28/01



2325 Orchard Parkway  
San Jose, CA 95131

**TITLE**

**40P6**, 40-lead (0.600"/15.24 mm Wide) Plastic Dual In-line Package (PDIP)

**DRAWING NO.**

40P6

**REV.**

B



9.3 44M1

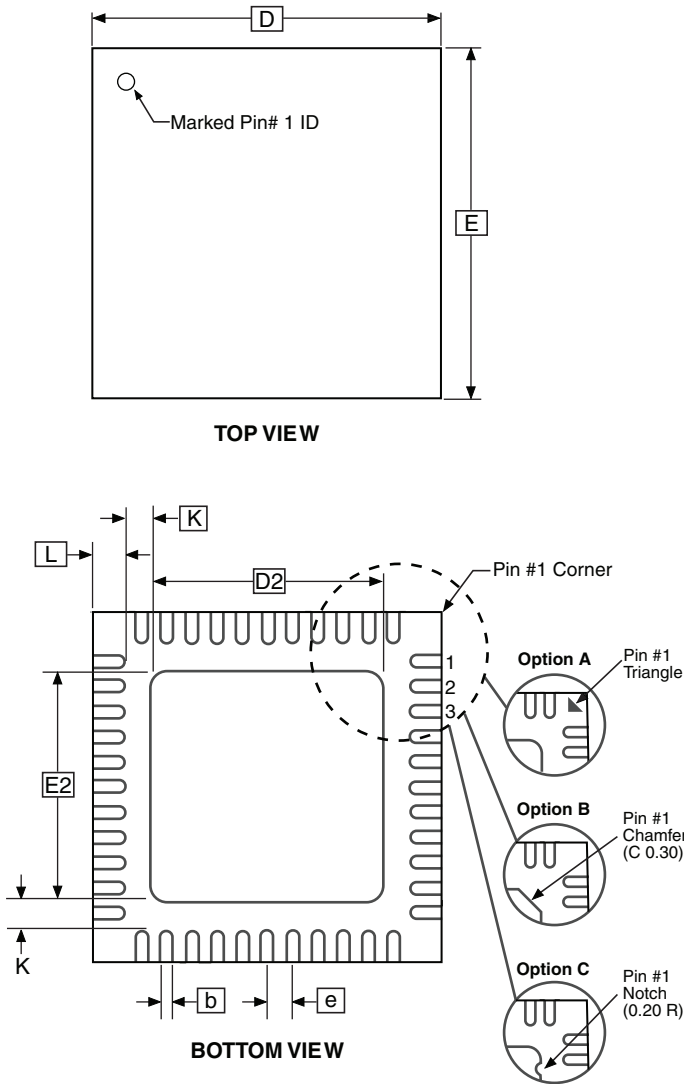

**COMMON DIMENSIONS**  
(Unit of Measure = mm)

| SYMBOL | MIN      | NOM  | MAX  | NOTE |
|--------|----------|------|------|------|
| A      | 0.80     | 0.90 | 1.00 |      |
| A1     | –        | 0.02 | 0.05 |      |
| A3     | 0.20 REF |      |      |      |
| b      | 0.18     | 0.23 | 0.30 |      |
| D      | 6.90     | 7.00 | 7.10 |      |
| D2     | 5.00     | 5.20 | 5.40 |      |
| E      | 6.90     | 7.00 | 7.10 |      |
| E2     | 5.00     | 5.20 | 5.40 |      |
| e      | 0.50 BSC |      |      |      |
| L      | 0.59     | 0.64 | 0.69 |      |
| K      | 0.20     | 0.26 | 0.41 |      |

Note: JEDEC Standard MO-220, Fig. 1 (SAW Singulation) VKKD-3.

9/26/08



**Package Drawing Contact:**  
packagedrawings@atmel.com

**TITLE**  
44M1, 44-pad, 7 x 7 x 1.0 mm Body, Lead Pitch 0.50 mm, 5.20 mm Exposed Pad, Thermally Enhanced Plastic Very Thin Quad Flat No Lead Package (VQFN)

**GPC**

ZWS

**DRAWING NO.**

44M1

**REV.**

H

## 9.4 44MC

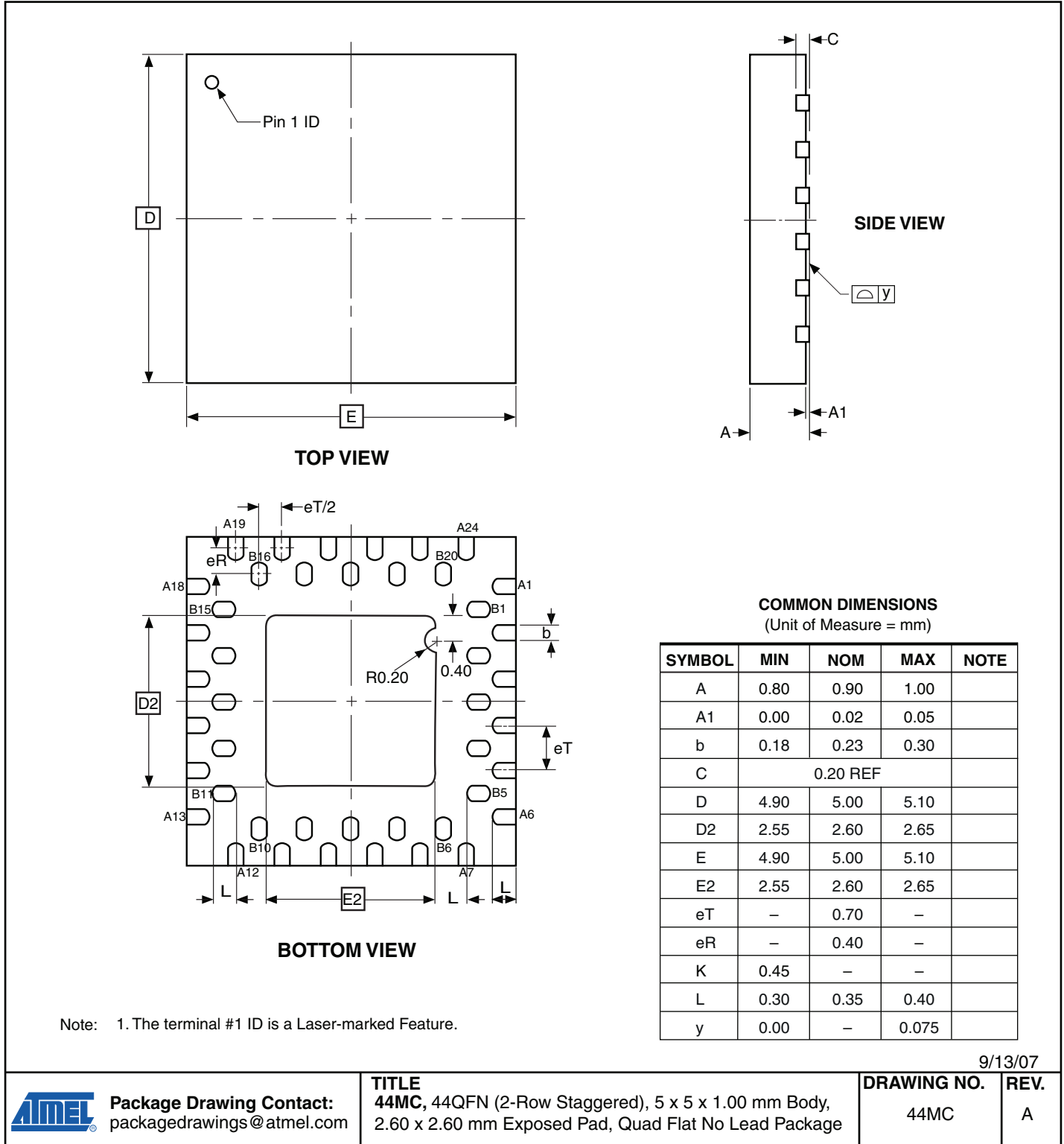

9.5 49C2

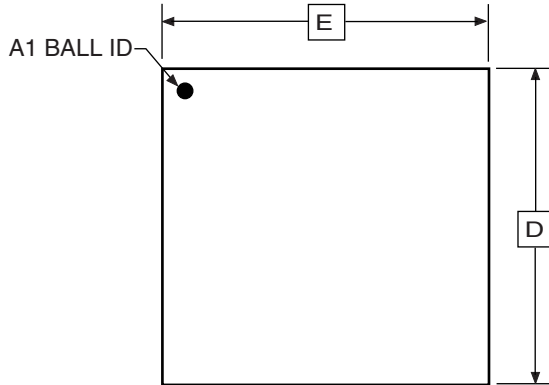

TOP VIEW

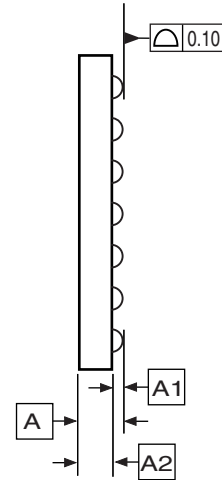

SIDE VIEW

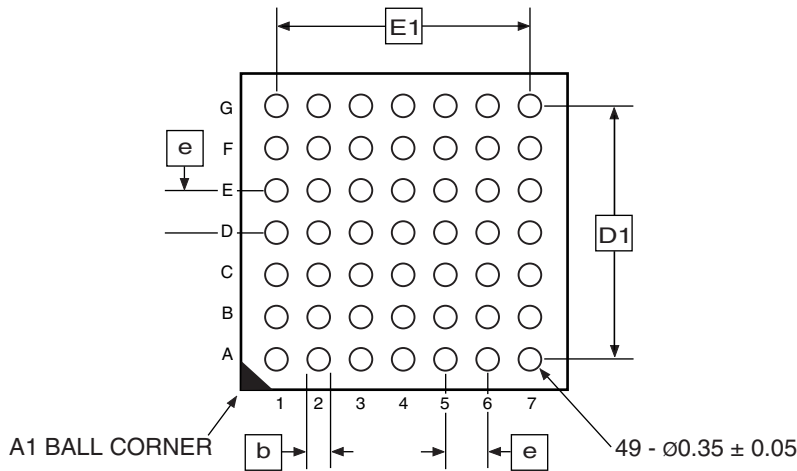

BOTTOM VIEW

COMMON DIMENSIONS  
(Unit of Measure = mm)

| SYMBOL | MIN      | NOM  | MAX  | NOTE |
|--------|----------|------|------|------|
| A      | -        | -    | 1.00 |      |
| A1     | 0.20     | -    | -    |      |
| A2     | 0.65     | -    | -    |      |
| D      | 4.90     | 5.00 | 5.10 |      |
| D1     | 3.90 BSC |      |      |      |
| E      | 4.90     | 5.00 | 5.10 |      |
| E1     | 3.90 BSC |      |      |      |
| b      | 0.30     | 0.35 | 0.40 |      |
| e      | 0.65 BSC |      |      |      |

3/14/08



Package Drawing Contact:  
packagedrawings@atmel.com

**TITLE**  
49C2, 49-ball (7 x 7 Array), 0.65 mm Pitch,  
5.0 x 5.0 x 1.0 mm, Very Thin, Fine-Pitch  
Ball Grid Array Package (VFBGA)

**GPC**

CBD

**DRAWING NO.**

49C2

**REV.**

A



## 10. Errata

### 10.1 ATmega164PA Rev. E

No known Errata.

### 10.2 ATmega324PA Rev. F

No known Errata.

### 10.3 ATmega644PA Rev. F

No known Errata.

## 11. Datasheet Revision History

Please note that the referring page numbers in this section are referred to this document. The referring revision in this section are referring to the document revision.

### 11.1 Rev. 8152F- 10/09

1. Added [Table on page 35](#), Capacitance for Low-frequency Oscillator.
2. Updated ordering information for 324PA.

### 11.2 Rev. 8152E- 08/09

1. Removed "[RAMPZ – Extended Z-pointer Register for ELPM/SPM](#)" on page 15.
2. Updated "[EEARH and EEARL – The EEPROM Address Register](#)" on page 24.
3. Updated "[Addressing the Flash During Self-Programming](#)" on page 282, by removing RAMPZ.
4. Updated "[Serial Programming Pin Mapping](#)" on page 309.
5. Updated "[Register Summary](#)" on page 415, by removing RAMPZ register.
6. Updated "[Instruction Set Summary](#)" on page 419, by removing ELPM mnemonics.
7. Updated ATmega164PA/324PA "[Ordering Information](#)" on page 422, MCU replaced by MCH.

### 11.3 Rev. 8152D- 08/09

1. Updated "[Ordering Information](#)" for ATmega644PA device on page 424.
2. Updated "[ATmega644PA Typical Characteristics](#)" on page 390

### 11.4 Rev. 8152C- 07/09

1. Updated "[Features](#)" on page 1 by inserting ATmega644PA device and updated the whole datasheet accordingly.
2. Updated "[Overview](#)" on page 5.
3. Inserted "[Comparison Between ATmega164PA, and ATmega324PA](#)" on page 6.
4. Updated all register description in "[AVR CPU Core](#)" on page 10.
5. Updated "[AVR Memories](#)" section included all register description.
6. Updated "[Calibrated Internal RC Oscillator](#)" on page 37.
7. Inserted "[ATmega164PA Boot Loader Parameters](#)" on page 291.
8. Updated "[Memory Programming](#)" section included "[Device and JTAG ID](#)" and "[Page Size](#)".
9. Inserted "[ATmega644PA DC Characteristics](#)" on page 329.

10. Inserted "ATmega644PA Typical Characteristics" on page 390.
11. Inserted "ATmega644PA" Ordering Information.
12. Updated "Errata" on page 430.

## 11.5 Rev. 8152B- 02/09

1. Updated "Features" on page 1 by inserting ATmega324PA device and updated the whole datasheet accordingly.
2. Updated "Overview" on page 5.
3. Inserted "Comparison Between ATmega164PA and ATmega324PA" on page 6.
4. Updated all register description in "AVR CPU Core" on page 10.
5. Updated "AVR Memories" section included all register description.
6. Updated "Calibrated Internal RC Oscillator" on page 37.
7. Inserted "ATmega324PA Boot Loader Parameters" on page 289.
8. Updated "Memory Programming" section included "Device and JTAG ID" and "Page Size" .
9. Inserted "ATmega324PA DC Characteristics" on page 327.
10. Inserted "ATmega324PA Typical Characteristics" on page 338.
11. Inserted "ATmega324PA" Ordering Information.
12. Updated "Errata" on page 402.

## 11.6 Rev. 8152A- 11/08

1. Initial revision (Based on the ATmega164P/324P/644P datasheet 8011K-AVR-09/08).
2. Changes done compared to ATmega164P/324P/644P datasheet 8011K-AVR-09/08:
  - New graphics in "Typical Characteristics" on page 337
  - New "Ordering Information" on page 395



## Headquarters

---

**Atmel Corporation**  
2325 Orchard Parkway  
San Jose, CA 95131  
USA  
Tel: 1(408) 441-0311  
Fax: 1(408) 487-2600

## International

---

**Atmel Asia**  
Unit 1-5 & 16, 19/F  
BEA Tower, Millennium City 5  
418 Kwun Tong Road  
Kwun Tong, Kowloon  
Hong Kong  
Tel: (852) 2245-6100  
Fax: (852) 2722-1369

**Atmel Europe**  
Le Krebs  
8, Rue Jean-Pierre Timbaud  
BP 309  
78054 Saint-Quentin-en-  
Yvelines Cedex  
France  
Tel: (33) 1-30-60-70-00  
Fax: (33) 1-30-60-71-11

**Atmel Japan**  
9F, Tonetsu Shinkawa Bldg.  
1-24-8 Shinkawa  
Chuo-ku, Tokyo 104-0033  
Japan  
Tel: (81) 3-3523-3551  
Fax: (81) 3-3523-7581

## Product Contact

---

**Web Site**  
[www.atmel.com](http://www.atmel.com)

**Technical Support**  
[avr@atmel.com](mailto:avr@atmel.com)

**Sales Contact**  
[www.atmel.com/contacts](http://www.atmel.com/contacts)

**Literature Requests**  
[www.atmel.com/literature](http://www.atmel.com/literature)

---

**Disclaimer:** The information in this document is provided in connection with Atmel products. No license, express or implied, by estoppel or otherwise, to any intellectual property right is granted by this document or in connection with the sale of Atmel products. **EXCEPT AS SET FORTH IN ATMEL'S TERMS AND CONDITIONS OF SALE LOCATED ON ATMEL'S WEB SITE, ATMEL ASSUMES NO LIABILITY WHATSOEVER AND DISCLAIMS ANY EXPRESS, IMPLIED OR STATUTORY WARRANTY RELATING TO ITS PRODUCTS INCLUDING, BUT NOT LIMITED TO, THE IMPLIED WARRANTY OF MERCHANTABILITY, FITNESS FOR A PARTICULAR PURPOSE, OR NON-INFRINGEMENT. IN NO EVENT SHALL ATMEL BE LIABLE FOR ANY DIRECT, INDIRECT, CONSEQUENTIAL, PUNITIVE, SPECIAL OR INCIDENTAL DAMAGES (INCLUDING, WITHOUT LIMITATION, DAMAGES FOR LOSS OF PROFITS, BUSINESS INTERRUPTION, OR LOSS OF INFORMATION) ARISING OUT OF THE USE OR INABILITY TO USE THIS DOCUMENT, EVEN IF ATMEL HAS BEEN ADVISED OF THE POSSIBILITY OF SUCH DAMAGES.** Atmel makes no representations or warranties with respect to the accuracy or completeness of the contents of this document and reserves the right to make changes to specifications and product descriptions at any time without notice. Atmel does not make any commitment to update the information contained herein. Unless specifically provided otherwise, Atmel products are not suitable for, and shall not be used in, automotive applications. Atmel's products are not intended, authorized, or warranted for use as components in applications intended to support or sustain life.

© 2009 Atmel Corporation. All rights reserved. Atmel®, Atmel logo and combinations thereof, AVR®, AVR® logo and others are registered trademarks or trademarks of Atmel Corporation or its subsidiaries. Other terms and product names may be trademarks of others.